

	Page
Specification Chart	2
Installation	
Safety	4
Dimensions	5
Cooling	7
Wiring	8
Quick Setup	10
Operation	11
Programming	
Group 0 -- Operation and Display	16
Group 1 -- Load and Motor	18
Group 2 -- Reference and Limits	22
Group 3 -- Functions and Timers	25
Group 4 -- Inputs and Outputs	27
Group 5 -- Serial Data Interface	31
Group 6 -- Service and Display	38
Appendix	
Motor Coil and Filter Options	41
PI Regulation	42
Parameter Groups	
Factory Default Settings	46
Customer Settings Chart	47



WARNING

The VLT® Series 2000 Adjustable Frequency Drive (AFD) contains dangerous voltages when connected to line voltage. Only a competent electrician should carry out the electrical installation.

Improper installation of the motor or the AFD may cause equipment failure, serious injury or death. Follow this manual and local and national safety codes.

It is possible for the VLT to start upon application of AC power. **DO NOT** attempt any maintenance on the VLT, motor or system machinery without verifying that the AC power has been disconnected.

DO NOT touch any electrical parts after the AC line has been disconnected for at least 14 minutes. This allows for capacitor discharge.

NOTE: The STOP key on the VLT keypad DOES NOT disconnect the AC line.

Caution:

The motor may start without warning during operation and programming of the parameters. Activate the STOP key on the VLT keypad when changing data.

It is the responsibility of the user or the person installing the AFD to provide proper grounding and branch circuit protection for incoming power and motor overload protection according to the National Electrical Code (NEC) and local codes.

Danfoss VLT® and CE Marking

Danfoss CE marks our VLT® Adjustable Frequency Drives (AFD) according to the Electro Magnetic Compatibility (EMC) Directive 89/336/EEC and Low-Voltage Directive 73/23/EEC.

When the installation specification is followed and shielded motor cables are used per instruction manuals provided with the drive, we guarantee the AFD complies with the EMC Directive 89/336/EEC.

Upon request we will issue a declaration of conformity to the EMC and low-voltage directives. A manufacturer's declaration for the Machinery Directive 89/392/EEC is also available.

VLT 2010-2030
Single-phase, 220-240 V
Three-phase, 208-240 V

NOTE:
 Minimum space above and below the unit is 4 inches.
 Minimum space to the sides of the unit is 0 inches.

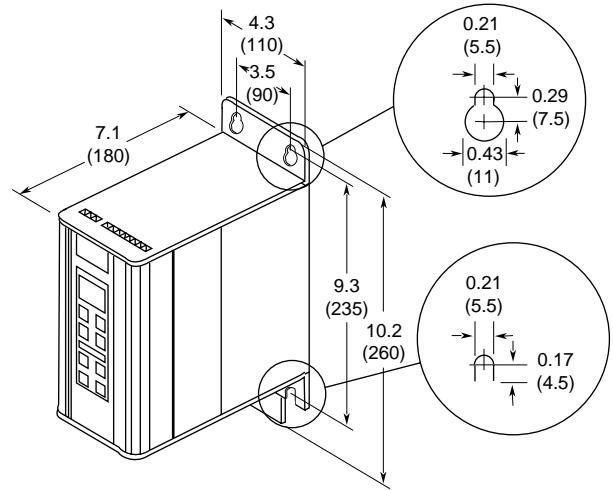

VLT 2010-2030 with module
Single-phase, 220-240 V
Three-phase, 208-240 V

NOTE:
 Minimum space above and below the unit is 4 inches.
 Minimum space to the sides of the unit is 0 inches.

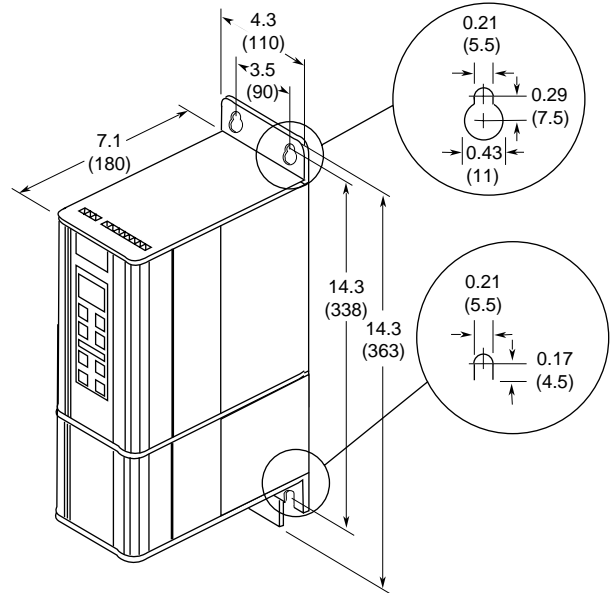

VLT 2020-2050
Three-phase, 380-415/460 V
VLT 2040-2050
Three-phase, 208-240 V

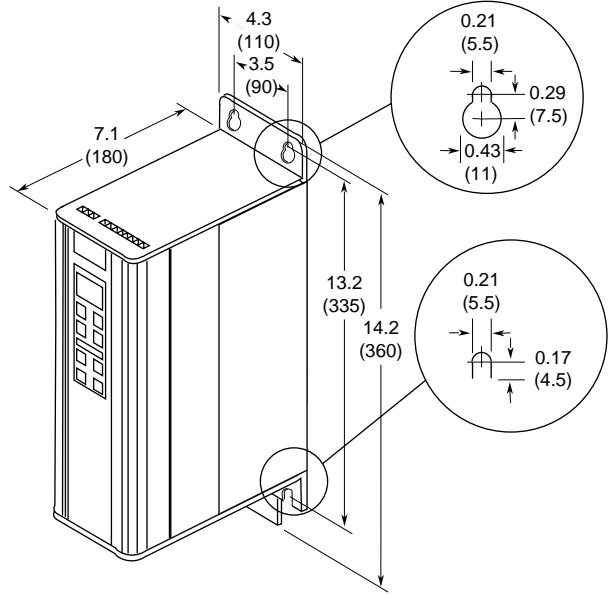

NOTE:
 Minimum space above and below the unit is 4 inches.
 Minimum space to the sides of the unit is 0 inches.

VLT 2020-2050 with module
Three-phase, 380-415/460 V

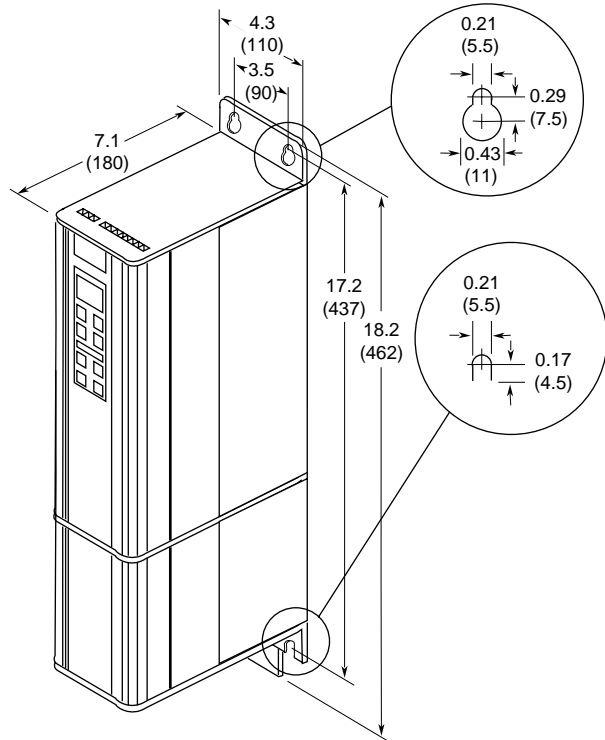

NOTE:
 Minimum space above and below the unit is 4 inches.
 Minimum space to the sides of the unit is 0 inches.

Mechanical Installation

The VLT Series 2000 is cooled by natural or forced air convection. Therefore air must be able to pass freely under and over the unit

The VLT adjustable frequency drive must be mounted on a flat vertical surface.

To enable the VLT to get rid of the cooling air, you must allow free air space both above and below the adjustable frequency drive.

The ambient temperature must not exceed 40°C so that the VLT can dispose of its power loss.

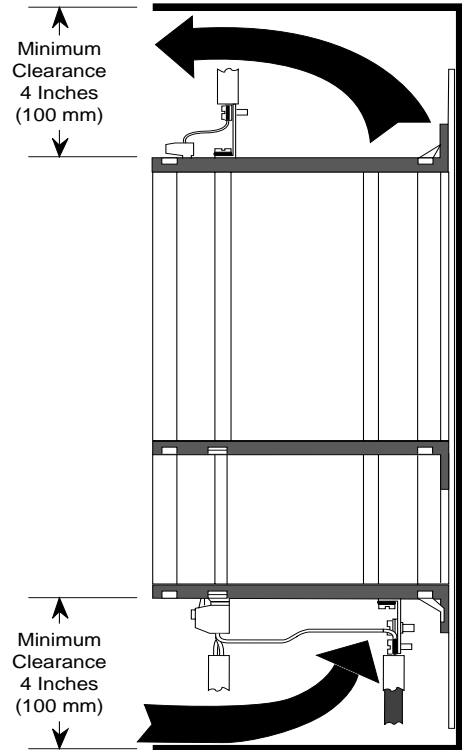

Side by Side Mounting

The VLT Series 2000 adjustable frequency drive can be installed side by side. There is no need for any space for cooling along the side of the enclosure.

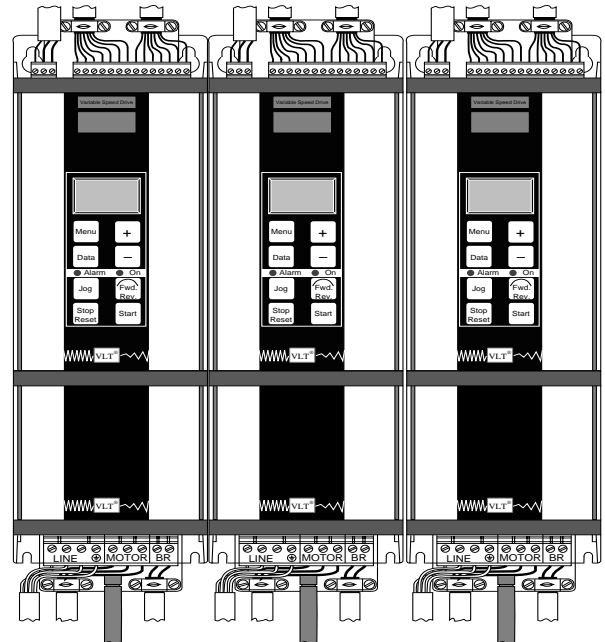

CAUTION:

It is the responsibility of the user or the person installing the drive to provide proper grounding and branch circuit protection for incoming power and motor overload. National Electrical Codes (NEC) and local codes must be observed.

The Electronic Thermal Relay (ETR) in UL listed VLT's provides class 20 motor overload protection in accordance with NEC in single motor applications, when parameter 315 is set to *Trip* [2] and parameter 107 is set to nominal motor (nameplate) current.

Prefuses

Prefuses must be installed in the AC line feeding the adjustable frequency drive.

The correct sizes and ratings can be found in the Specification Chart.

Wiring

Cables for the control signals and the brake cable must be shielded in order to comply with EMC specifications. The maximum cable length and the maximum cable cross section is listed in the Specification Chart.

Any motor cable shielding is connected to the ground terminals in the adjustable frequency drive and the motor. If non-shielded cables are used, the control inputs can occasionally be subject to signal disturbances. Normally such a disturbance will not affect the VLT.

Signal Wiring

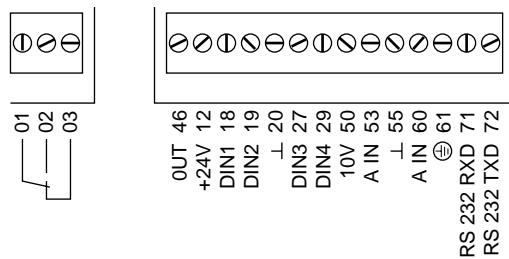

Line and Motor Wiring

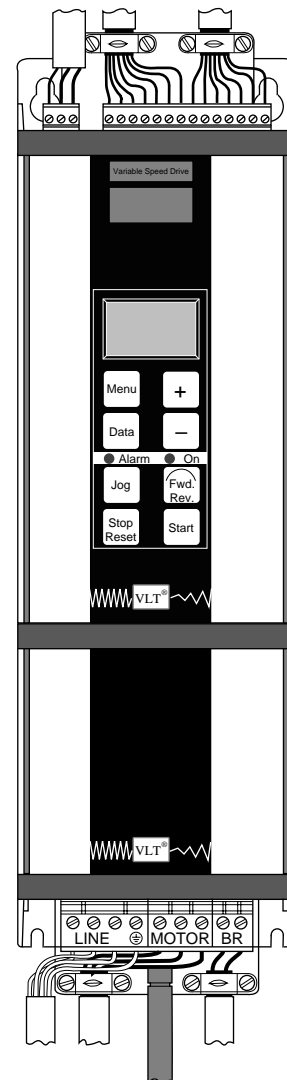
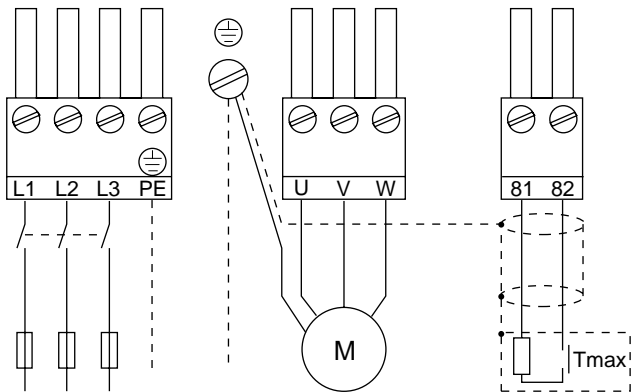

Typical Wiring Example

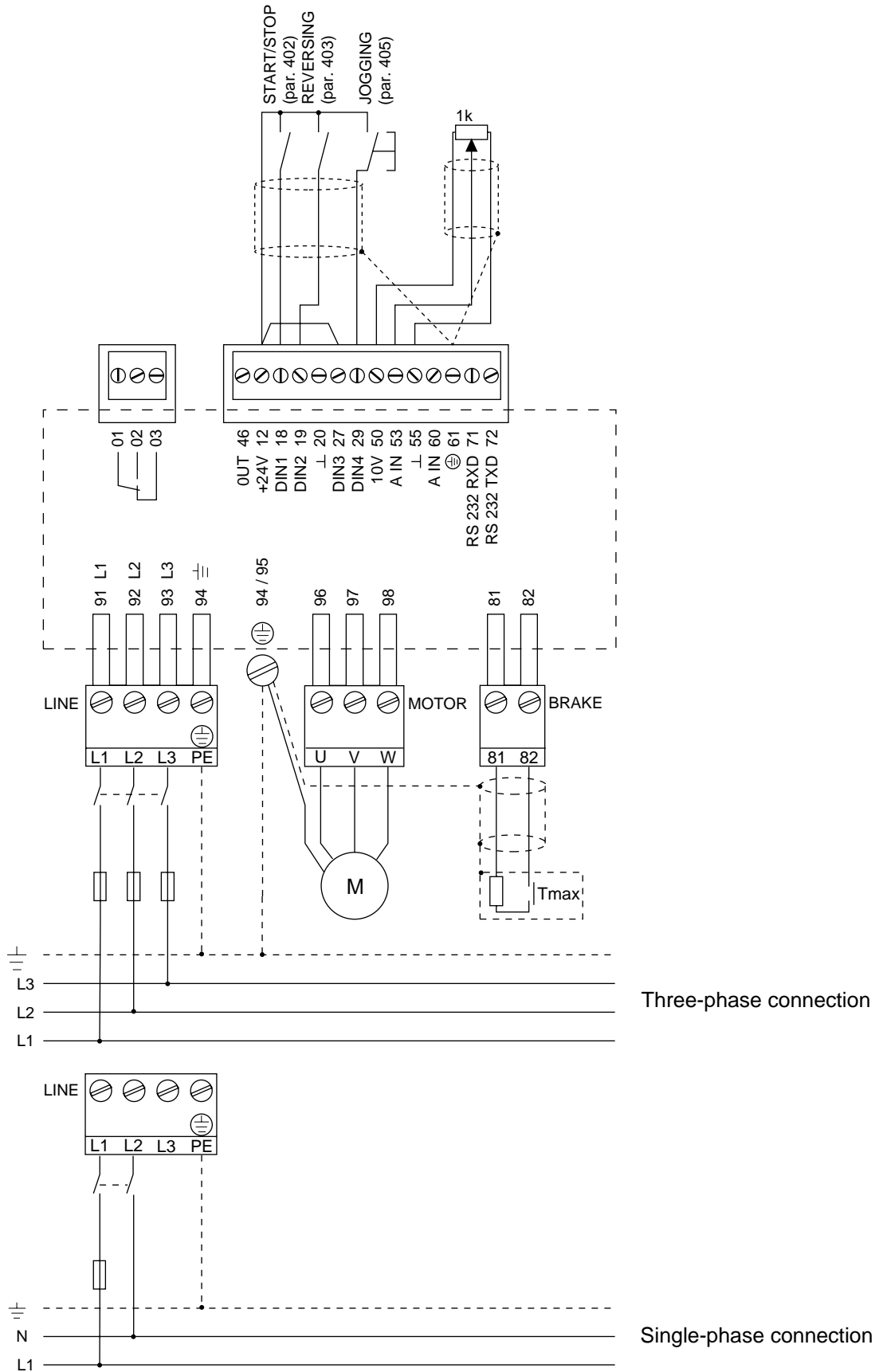

Quick Setup

If you know how to operate the VLT Series and are familiar with the menus and parameters, go directly to the How to Program section of this manual.

If you are not familiar with the VLT Series Adjustable Frequency Drive refer first to the Operation section of this manual.

How to Program

This setup is based on the assumption that you want your VLT to operate with the following:

1. External start/stop
2. Potentiometer connected for external speed control
3. Option to change rotation direction
4. Option to select a fixed speed (Jog)

NOTE: If you use a brake module, you must program parameter 300. If you want local operation via the display keys you must program parameters 003 and 004. To store the data press the "Menu" key.

If you have connected your VLT as shown in the Typical Wiring Example, you must program the parameters as listed in the chart below.

Standard motor with constant torque load without a brake module on the adjustable frequency drive

Step	Parameter	Designation	Settings	Display Indication
1	000	Language	Choose <i>English</i>	ENGLISH
2	103	Motor output	Read motor plate	
3	104	Motor voltage	Read motor plate	
4	105	Motor frequency	Read motor plate	
5	201	Minimum frequency	Set wanted frequency	
6	202	Maximum frequency	Set wanted frequency	
7	215	Ramp up 1	Set wanted ramping time	
8	216	Ramp down 1	Set wanted ramping time	
9		Start the adjustable frequency drive	This is done by supplying terminals 18 and 27 with 24 VDC from the adjustable frequency drive's terminal 12 or by using an external 24 VDC voltage.	

If a brake module is mounted, program the following parameters

Step	Parameter	Designation	Settings	Display Indication
1	300	Brake function	If a brake module is used, choose <i>Applied</i>	APPLIED
2		Start the adjustable frequency drive	This is done by supplying terminals 18 and 27 with 24 VDC from the adjustable frequency drive's terminal 12 or by using an external 24 VDC voltage.	

If you want local operation and start, program the following parameters

Step	Parameter	Designation	Settings	Display Indication
1	003	Operation site	Choose <i>Loc/ext stop</i>	LOC/EXT STOP
2	004	Local reference	Record wanted output frequency by means of the "+" and "-" keys	

VLT Control Panel

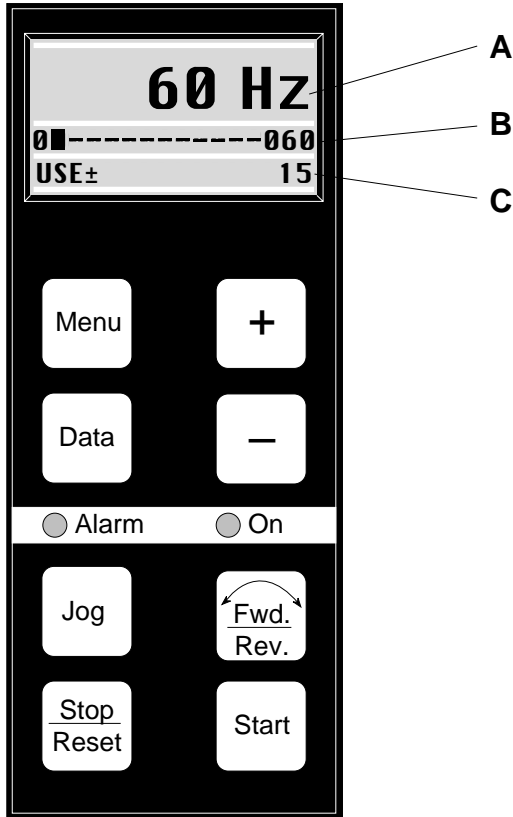

All Danfoss VLT Series 2000 AC drives utilize the same control card throughout the entire HP range. The VLT control panel consists of a keyboard and a display.

The keyboard is used for two purposes: local control and programming. The display communicates VLT, motor and application information to the operator.



Located on the control panel is a red and green status LED. When the green status LED is illuminated, there is AC power applied to the VLT. The red LED is used for alarm indications. In an ALARM MODE, the LED will flash.

The display is a three-line LCD display. Line A is used for operating displays. It shows the value corresponding to the setting in DISPLAY MODE. The set value remains in the display line during programming of parameters. Line B shows information about parameters and direction of motor operation. Line C shows information about status and setup or data value.

Programming Keys

 is used to enter MENU MODE from either DATA MODE or DISPLAY MODE. MENU is also used for entering a specific group of parameters.

 is used for entering DATA MODE or DISPLAY MODE from MENU MODE. DATA is also used to move the cursor in data values.

The  and  keys are used for scrolling through Groups, Parameters and Data Value selections. Additionally these keys are used for speed up and down when operating in Local mode.

Operator Keys

Four keys are provided for local control:

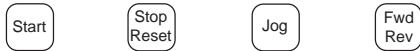



With the exception of the Start key the keys can be programmed to be enabled or disabled to prevent unwanted use in certain applications.



Local Stop: Local Stop is accomplished by pressing the Stop/Reset key on the front control panel. The local stop command has been designed to override all run signals whether local or remote. When a local stop has been made the top line of the display will flash. The only way to resume running from a local stop condition is to initiate a local start.

Local Forward/Reverse: Local Forward/Reverse will be automatically disabled if remote operation is selected. In remote, it is not possible to make direction changes from the keypad.

Operational Modes

The VLT will be in DISPLAY MODE when the motor is running in normal operation. DISPLAY MODE provides various information concerning the current status of the VLT and motor.

The  and  keys are used to scroll among

The MENU MODE is used to select and change operating parameters. The  and  keys are used in the

MENU MODE to select a parameter group or an individual parameter or the data value of a given parameter.

the 12 main display readouts:

- Reference
- Frequency Hz
- Display Feedback unit
- Current A
- Torque %
- Power kW
- Power HP
- Energy kWh
- Output voltage V
- DC voltage V
- Motor ETR value %
- Inverter ETR value %

Group	Description	Parameters
0	Operation and Display	000-099
1	Load and motor	100-199
2	Reference and limits	200-299
3	Functions and timers	300-399
4	Input and Output	400-499
5	Serial data interface	500-599
6	Service and diagnostics	600-699

Parameter Numbering

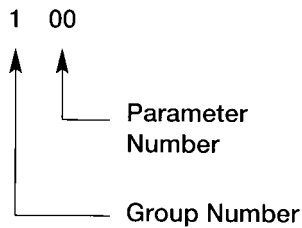



The parameter number consists of three digits as shown.



The left digit indicates the Group, and the two digits at the right specify the parameter number in the specific Group.

Moving through the Program

After the first power up, the drive is in DISPLAY MODE. To program the VLT's various Groups, use the MENU key to enter the MENU GROUP MODE.

To travel through the available Groups, use the  key followed by the  or  keys.

Changing a Parameter number in a Group

Parameters in each group can be entered in the selected group by also using the  key followed by  or  key.





Changing a Numerical Data Value

The Data Value can be a continuous (numerical) value of figures within a specified range (i.e., volts, Hz, etc.), or it can be a discrete value represented by the text.

The new data value will be stored in the software when leaving the DATA MODE.

Please Note: It is necessary to press  to stop the motor before changing the data value of some parameters.

If the data value of the chosen parameter is a discrete value, a text will appear in the display. The text shown represents the chosen parameter. In order to change it, press

 or  . All the other data value words that can be chosen will be shown one at a time by using the  or  key.

Due to space considerations, several words have been abbreviated on the display.

When leaving the DATA MODE, the word shown in the display will be stored.

Please Note: In order to change the data value of some parameters, it is necessary to press  .

Time-out

If the VLT is left in DATA MODE, a 20 second time-out will prevent unwanted change of data.

The software leaves DATA MODE after 20 seconds if no operation is recorded.

It is possible to return to DATA MODE and program the parameter that was blocked by the time-out with a single

stroke on  .

Note: The 20 second time-out does not occur in parameter 004, Local Reference.

Operational Modes

Display Mode

- Shows value and unit —
- Defines the display —
- Status, and source of control —



- Direction of rotation
- Setup number

Menu Mode

- Parameter number flashes —
- 0. = Cursor flashes



- Parameter group
- Name

Parameter Mode

- Flashing parameter numbe —
- 00 = Cursor flashes —
- Selected data value —



- Parameter name
- setup number

Data Mode

- E = Cursor flashes —
- Selected data value



- Parameter name
- Setup number

NOTE: To store the newly selected data value, you must quit Data group, by pressing "Menu".

Alarm Mode

- Reset mode —
- Cause of alarm —

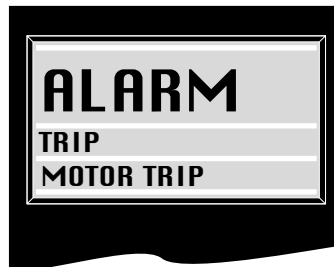

NOTE: If TRIP is displayed the operation has stopped and you must press the "Reset" key to reset the VLT.

NOTE: If TRIP LOCKED is displayed you must switch off the VLT and switch it on again. Press the "Reset" key to reset the VLT.

The figure below shows how to switch between the different groups.

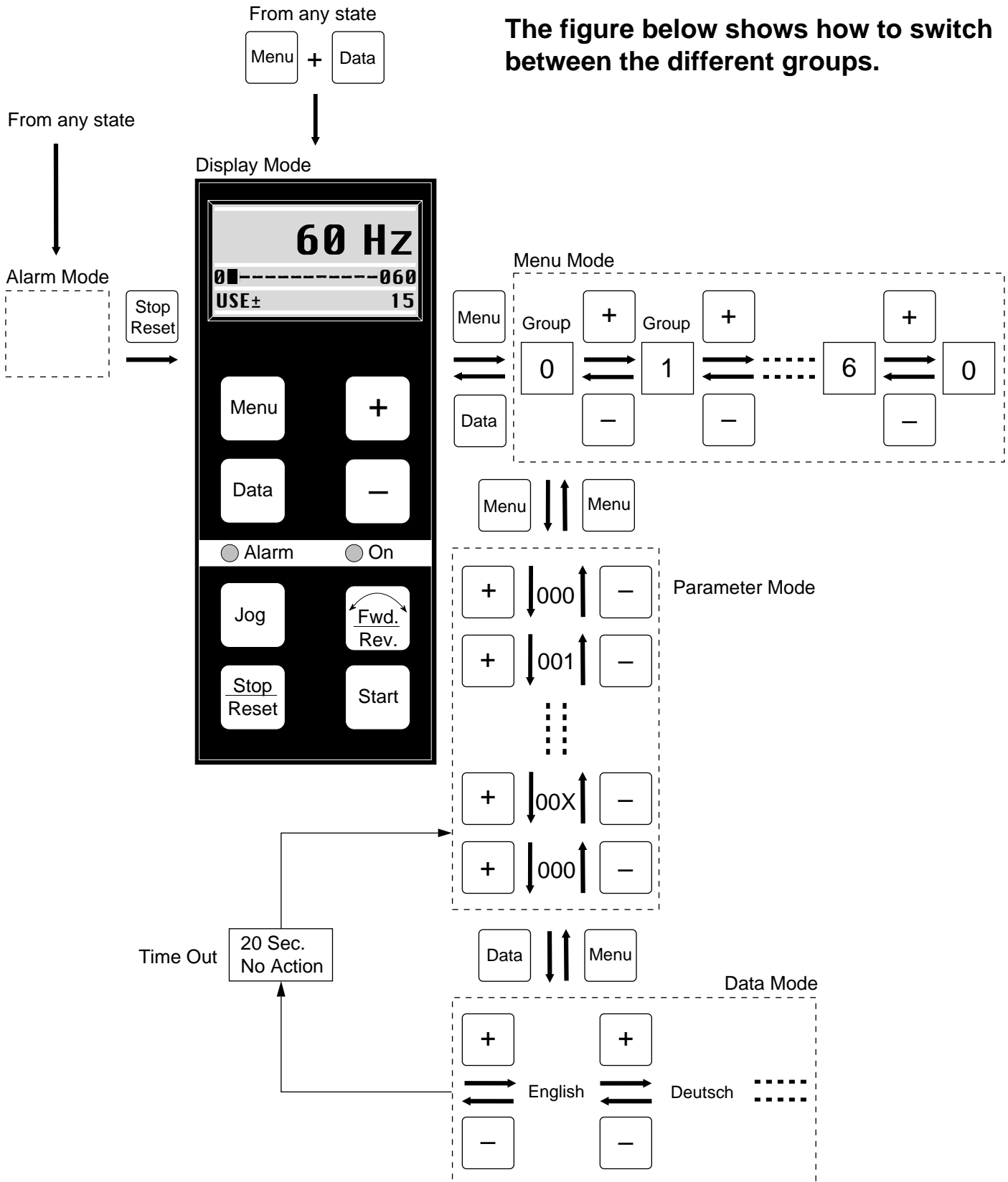

Group 0 -- Operation and Display

000 Language (LANGUAGE)

Value:

★ English (ENGLISH)	[0]
German (DEUTSCH)	[1]
French (FRANCAIS)	[2]
Danish (DANSK)	[3]

Function and Description:

Determines the language of the display. You can choose between *English, German, French and Danish.*

001 Menu Setup Select (MENU SETUP)

Value:

★ Setup 1 (SETUP 1)	[1]
Setup 2 (SETUP 2)	[2]
Multi-setup (MULTI SETUP)	[5]

Setup	Terminal 29
1	0
2	1

Function:

You can select a menu setup which is different from the factory setting and store it in *Setup 1 or Setup 2.*

Description:

You start by selecting the setup you want to make or alter. You can choose between *Setup 1 or setup 2.* Then you can alter any data value you like. Your alterations make a setup different from the factory setting. If you choose *Multi-setup* you can switch between the two setups via terminal 29. The parameters which can be chosen for the two setups have been specially selected. Refer to the Parameter/Default Settings chart in the back of this manual.

002 Setup Copy (MENU SET COPY)

Value

★ No copying (DO NOT COPY)	[0]
Copy setup 1 to 2 (COPY 1 TO 2)	[6]
Copy to 2 to 1 (COPY 2 TO 1)	[7]
Copy from fact. setting to 1 (Fact. setting →1)	[8]
Copy from fact. setting to 2 (Fact. setting →2)	[9]

Function:

You can copy *Setup 1 to Setup 2* and vice versa. You can always copy the factory setting back to *Setup 1 or Setup 2.*

Description:

The copying starts when you have entered the desired copying function and Data mode is left by pressing the "Menu" key, or after 20 seconds of no activity. Line 3 in the display flashes while copying is in progress. Time out does not activate the copying function.

003 Operation Site (LOCAL /REMOTE)

Value:

★ Remote (REMOTE)	[0]
Local with external stop (LOC/EXT./STOP)	[1]
Local (LOCAL)	[2]
Local and remote (LOCAL - REMOTE)	[3]

Function:

You can choose four different operation sites: *Remote, Local with external stop, Local and Local and remote.*

Description:

If you choose *Remote*, you can control the adjustable frequency drive via the control terminals. However, you can still use the stop key of the control panel (provided you have not chosen to disable this function in parameter (007). If you choose *Local with external stop* you must disconnect the connection between terminals 12 and 27 to activate stop. *Local with external stop* can only be chosen if *Motor coasting, Quick stop, Reset and motor coasting or Stop* have been chosen in parameter 404 (terminal 27). Choose *Local* if you want to operate the unit via the keyboard (must be activated in parameter 007). *Local and remote* adds local and external reference. This function is selected for access to local reference even when the unit is operated remotely.

★ = ROM default setting. Text in () = display text. Figures in [] are used when communicating with the bus.

004 Local Reference (LOCAL SPEE)

Value:

 0 to f_{MAX}

Function:

You choose *Local reference* if you want to set the speed (frequency) via the control panel.

Description of choice:

To use this parameter you must choose *Local with external stop or Local and remote* in parameter 003. the output frequency of the adjustable frequency drive can be changed by means of the "+" and "-" keys. If the AC line is disconnected the value changes to 0.00. Parameter 004 cannot be controlled via the serial bus, RS 232. There is no automatic switch back to Parameter Group from this parameter. In parameter 010 you can lock data changes in parameter 004.

005 Display Value (VALUE AT M)

Value:

 1 to 9999 ★ 1000

Function:

You can choose to have the speed/frequency displayed without the unit Hz behind the value.

Description of choice:

The value will only be read out if *Display* is selected in Display Group. It is not possible to change Hz to another unit.

006 Local Reset (LOCAL RESE)

Value:

Disable (DISABLE)	[0]
★ Enable (ENABLE)	[1]

007 Local Start/Stop (LOCAL START/STOP)

Value:

Disable (DISABLE)	[0]
★ Enable (ENABLE)	[1]

008 Local Reversing (LOCAL/FWD/REV)

Value:

★ Not possible (DISABLE)	[0]
Possible (ENABLE)	[1]

009 Local Jog (LOCAL JOG)

Value:

Disable (DISABLE)	[0]
★ Enable (ENABLE)	[1]

010 Local Reference (LOC REFERE)

Value:

Disable (DISABLE)	[0]
★ Enable (ENABLE)	[1]
Enable and save (ENABLE AND SAVE)	[2]

Function:

You can enable/disable the function via the control panel. You also can choose whether it must be possible to change the output frequency via parameter 004.

Description:

If you choose *Disable* in parameter 006, 007, 008 or 009 you cannot activate the function via the control panel. If you choose *Disable* in parameter 010 the output frequency cannot be changed via parameter 004. You can prevent data change by setting parameter 013 to *Locked*. If you choose *Enable* and saves a change of local speed reference will be saved automatically after 15 sec.

013 Data Change Lock (DATA CHC. LOCK)

Value:

★ Not locked (NOT LOCKED)	[0]
Locked (LOCKED)	[1]

Function:

There is a way to avoid unintended programming.

Description:

If you choose *Locked* you cannot make any data change in any parameter. However, it is still possible to change the local reference. If data change is attempted with data change lock, the display shows: DATA LOCKED.

Group 1 -- Load and Motors

101 Speed Control (SPEED CONT)

Value:

Open loop (OPEN LOOP)	[0]
★ Slip comp. (SLIP COMP)	[1]
Closed loop (CLOSED LOOP)	[2]

Function:

You can choose among three different kinds of speed control: *Open loop*, *Slip compensated* and *Closed loop*.

Description:
Choose *Slip compensation* for normal operation, where the speed must be constant no matter what the load is. Choose *Open loop* when the motors used are parallel connected or when synchronous motors are used.
Choose *Closed loop* when you want operation with process feedback. For closed loop operation you must choose the feedback type in parameter 114 (current, voltage or pulses).

102 Setting of Current Limit (SET CUR.LI)

Value:

★ Pre-programmed value (VALUE SET)	[0]
Voltage signal (10VDC SIGNAL)	[1]
Current signal (20 mA SIGNAL)	[2]

Function:

You can choose to control the speed by means of the current limit. This makes indirect torque control possible. The current limit is set in parameter 209, or by means of a current or voltage signal in parameter 412 or parameter 413.

Description:
Choose between controlling the current limit via parameter 209 or one of the analog inputs, terminal 53 or 60. *10V/20 mA* corresponds to 160% current (2030: 140%).
Do not select the same signal for PI control.

103 Motor Power (MOTOR POWE)

Value:

Under size	[0]
★ Nom. size	[1]
Over size	[2]

Function:

This parameter allows a choice of the kW value that best matches the rated motor power. The factory setting will be for the nominal kW equivalent of the horsepower size on the drive nameplate.

103 (continued)

Description:
Check the rated motor power on the motor nameplate. If it is not equal to the nominal horsepower rating on the drive nameplate, select the most appropriate size (1 HP = 0.746 kW). Parameters 107, 108, 109, 110, 111 and 112 change automatically when the value in parameter 103 is changed.

104 Motor Voltage (U_{M,N})(MOTOR VOLT)

Value:

<i>Only 200-230 V units</i>	
200 V	[0]
208 V	[1]
★ 220 V	[2]
230 V	[3]
240 V	[4]
<i>Only 380-460 V units</i>	
380 V	[0]
★ 400 V	[1]
415 V	[2]
440 V	[3]
460 V	[4]

Function:

The rated voltage that most closely matches the motor nameplate voltage can be selected.

Description:
You can choose among different voltage values. The value is selected on the basis of the data on the motor plate. Parameters 107, 108, 109, 110, 111 and 112 change automatically when the value in parameter 104 is changed.

105 Motor Frequency (f_N)(MOTOR FREQ)

Value:

★ 50 Hz (50 Hz)	[0]
60 Hz (60 Hz)	[1]
87 Hz (87 Hz)	[2]
100 Hz (100 Hz)	[3]

Function:

Choose the frequency that corresponds to the rated motor frequency.

Description:
You can choose among 4 different frequency values. The value is selected on the basis of the data on the type plate of the motor.
The U/f ratio in parameter 111 is changed automatically.

★ = ROM default setting. Text in () = display text. Figures in [] are used when communicating with the bus.

107 Motor Current (MOTOR CURR)

Value:

$$I_{MAG} \text{ (par. 108)} - I_{VLT, MAX} \text{ (par. 209)}$$

Function:

It is important to specify the rated motor current because it is used in part to calculate torque and thermal motor protection, (ETR),

Description:

The rated motor current, which can be seen from the motor nameplate, must be entered. This is also chosen in Quick Set Up Menu step 2.

108 Motor Magnetizing Current (MOTOR MAG AMP)

Value:

$$0.3 - I_{M,N} \text{ (par. 107)}$$

Function:

The VLT uses the value for different calculations such as compensation.

Description:

If the factory setting is unsuitable, the motor current on running idle should be measured with suitable amperemeter (RMS). The magnetizing current is then set to the measured value.

109 Start Voltage (START VOLT)

Value:

$$0 \text{ to } (V_{M,N} + 10\%)$$

Function:

By increasing the start voltage, a high start torque can be obtained. Small motors (<1 HP) normally require a high start voltage. When motors are connected in parallel, it may be desirable to increase the starting torque.

Description:

Do not forget to consider that the motor must be able to start with the required torque:

1. Choose a value to make start possible with the load in question.
2. Reduce value until starting up with the given load is just possible.
3. Choose a value where operation in the rest of the frequency range is possible at the lowest possible current consumption.

If the start voltage makes normal operation impossible, you can change the V/f ratio in parameter 111.



WARNING: If the use of start voltage is excessive, it can lead to magnetic saturation and motor overheating.

★ = ROM default setting. Text in () = display text. Figures in [] are used when communicating with the bus.

110 Start Compensation (START COMP)

Value:

0.00 - 99 V/A

Function:

Using this parameter you can make a load dependent torque adaptation. This is for example used for motors and applications where there is a large difference between the motor's full-load current (parameter 107) and no-load current (parameter 108).

Description:

If the factory setting is not sufficient, you can set the parameter so that the motor can start at the actual load. You can also combine start compensation with parameter 109.



WARNING: Should not be used with synchronous motors and parallel-coupled motors and where quick load changes may occur. To avoid instability do not increase the value more than necessary.

111 V/f Ratio (V/F RATIO)

Value:

0.00 - 20 V/Hz

Function:

Using this parameter you can change the linear ratio between voltage (V) and frequency (f) to correct motor magnetization, optimal dynamics, accuracy or efficiency.

Description:

Use this parameter only if you cannot record the correct motor data in parameters 104 and 105.

The value can be calculated as follows:

$$V/f = \frac{\text{Motor voltage (para. 104)}}{\text{Motor frequency (para. 105)}}$$

The value of the factory setting is based on no-load operation. Therefore it is lower than the value calculated. The compensation will give the necessary voltage supplement.

For factory settings refer to the Parameter Chart in the back of this manual.

112 Slip Compensation (SLIP COMP.)

Value:

0.0 - 20 Hz

Function:

Slip Compensation increases the output frequency and voltage of the VLT adjustable frequency drive with an increasing load to compensate for the motor's increasing slip (loss). This achieves a load-independent speed.

Description:

Choose a value so that the speed remains constant when the load increases. If the value is too high the speed increases with the load. This may lead to unstable motor operation.

When you use synchronous motors and motors connected in parallel, set slip compensation to 0 Hz. Slip compensation should be avoided in case of high dynamics.

114 Feedback Signal (FEEDBACK T)

Value:

- Voltage (VOLTAGE) [0]
- ★ Current (CURRENT) [1]
- Pulses (PULSES) [2]

Function:

This parameter allows a choice of process feedback signal in a closed loop system, as chosen in parameter 101. It has no effect if parameter 101 is set to OPEN LOOP. For further information, see the section on the PID controller.

Description of choice:

If a PID controller is used, one of the inputs on terminal 29 (parameter 405), terminal 53 (parameter 412) or terminal 60 (parameter 413) must be used for the feedback signal. The same type of signal cannot be the reference signal.

119 FF Factor (FEED FWD F)

Value:

0 to 500% ★ 100%

Function:

This parameter is used in connection with a PI controller. The FF factor makes a large or small part of the reference signal around the PID controller so that the PI controller only affects part of the control signal. Any change of the setpoint will affect the motor rpm directly. The FF factor gives high dynamics at changes of the setpoint and less overswing.

Description of choice:

You can choose the required % value in the interval f_{MIN} - f_{MAX} . Choose a value above 100% if the setpoint variations are only minor.

120 Control Range (CONTRL RAN)

Value:

0 to 100% ★ 100%

Function:

The regulator range (bandwidth) limits the output from the PID controller as a % of f_{MAX} .

Description of choice:

A desired % value of f_{MAX} can be selected. If the regulator range is reduced, speed variations will become smaller during initial adjustment.



WARNING: The output frequency is limited by $0.9 \times f_{MIN}$ and $1.1 \times f_{MAX}$ no matter what the bandwidth setting is. The controller can therefore be active without affect the output frequency can exceed f_{MAX} by 10%.

121 Proportional Gain (PROPRT/L G)

Value:

0.01 to 10.00 ★ 0.01

Function:

The proportional gain sets the amplification factor of the error (the difference between the feedback signal and the setpoint).

Description of choice:

Quick regulation is obtained at a high amplification, but if the amplification is too high, the process may become unstable due to overshoot.

122 Integral Time (INTEGRAL T)

Value:

0.01 to 7200 sec. ★ OFF

Function:

The integral time determines how long the PI controller takes to correct the fault. The integral time results in a delay of the signal, and therefore has a dampening effect that will improve stability.

Description of choice:

Quick regulation is obtained through a short integral time. However, if this time is set too short, the process will become unstable. If the integral time is set long, regulation becomes unnecessarily slow. *Off* means that the function is inactive.

★ = ROM default setting. Text in () = display text. Figures in [] are used when communicating with the bus.

125 Feedback Factor (FEEDBACK F)

Value:

0 to 500%

★ 100%

Function:

The feedback factor is used if the transmitter cannot be selected optimally for the scale range of the setpoint.

Description of choice:

This parameter is only used if the feedback signal in parameter 114 is not of a suitable level. If you choose *100%* the feedback signal is not changed.

Group 2 -- References and Limits

200 Frequency Range (FREQUE RANGE)

Value:

- ★ 0 to 120 Hz [0]
- 0 to 500 Hz [1]

Function:

Using this parameter you can set and thus limit the output frequency range of the VLT adjustable frequency drive.

Description:

In most cases you can use 0-120 Hz.



WARNING: Only choose 0-500 Hz if you use special motors designed for high speeds.

201 Minimum Frequency (MIN FREQUE)

Value:

- 0.0 to f_{MAX} ★ 0

Function:

Choose the minimum frequency that corresponds to the minimum speed at which the motor is to run. The minimum frequency can never be higher than the maximum frequency, f_{MAX} .

Description:

A value from 0.0 Hz to the max. frequency (f_{MAX}) selected in parameter 202 can be chosen. This is also chosen in Quick Set Up Menu step 5.

202 Maximum Frequency (MAX FREQUE)

Value:

- 0.0 - value in para. 200 ★ 60 Hz

Function:

Choose a maximum frequency that corresponds to the maximum speed at which the motor is to run. The maximum frequency can never be lower than the minimum frequency, f_{MIN} .

Description:

A value from f_{MIN} to the value selected in parameter 200 for f_{MAX} (120 Hz or 500 Hz) This is also chosen in Quick Set Up Menu step 6.



When the PI controller is active the maximum frequency can be exceeded by 10%. The same applies when slip compensation is active.

203 Jog Frequency (JOG FREQUE)

Value:

- 0.0 to f_{MAX} ★ 10 Hz

Function:

The jog frequency is the fixed output frequency at which the drive runs when the jog function is activated.

Description:

The jog frequency can be selected to be lower than f_{MIN} (parameter 201) but the highest output frequency is limited by f_{MAX} (parameter 202).

204 Digital Reference Type (DIG. REF.)

Value:

- ★ Sum (SUM) [0]
- Relative (RELATIVE) [1]

Function:

The digital references are generated internally in the unit and presented as a percentage of the difference between the f_{MAX} and f_{MIN} selected in parameters 201 and 202, added to f_{MIN} .

Description:

If *Sum* is selected, one of the digital references (parameters 205-208) is added as a percentage of the difference between f_{MAX} and f_{MIN} with the other references. If *Relative* is selected, one of the digital references (parameters 205-208) is added as a percentage of the sum of the other references.

205 Digital Reference 1 (REF. 1 DIG)

Value:

- 100.00% to +100.00% ★ 0 % of $f_{MAX} - f_{MIN}$

206 Digital Reference 2 (REF. 2 DIG)

Value:

- 100.00% - +100.00% ★ 0 % of $f_{MAX} - f_{MIN}$

207 Digital Reference 3 (REF. 3 DIG)

Value:

- 100.00% - +100.00% ★ 0 % of $f_{MAX} - f_{MIN}$

★ = ROM default setting. Text in () = display text. Figures in [] are used when communicating with the bus.

208 Digital Reference 4 (REF. 4 DIG)

Value:

 -100.00% - +100.00% ★ 0 % of $f_{MAX} - f_{MIN}$

Function:

The digital speed references are generated internally in the unit and presented as a percentage of the difference between the f_{MAX} and f_{MIN} selected in parameters 201 and 202, added to f_{MIN} .

Description:

By means of terminal 29 you can switch between the other references (terminal 29 = 0 V) and the sum of the other/digital references (terminal 29 = 24 V).

You must select Digital reference in parameter 402 and 403 to file one of the digital references:

Terminal 18/27	Terminal 19	
0	0	Digital reference 1
1	0	Digital reference 2
0	1	Digital reference 3
1	1	Digital reference 4

209 Current Limit (CURRENT LI)

Value:

 0.3 to $I_{VLT,MAX}$

Function:

Use this parameter to set the maximum intermittent output current. If the current limit is exceeded, the output frequency is reduced until the current falls to below the current limit. The output frequency will not increase to the reference level until the current has fallen below the current limit.

Description of choice:

The value set at the factory corresponds to a load which is 160% (VLT 2030, 3Ø 208-240 V: 140%) of the rated output current. If the current limit is to be used as motor protection, the rated motor current must be programmed. Parameter 310 determines the length of time that the drive will run in current limit before an overcurrent fault. The load range between 100 and 160% can be programmed, but it is only intended for intermittent operation therefore the unit can only give an output of 160% (VLT 2030, 3Ø 208-240 V: 140%) for 60 seconds. The intermittent operating time will be extended as the load drops below 110%, and becomes unlimited at 100%.



If the switching frequency is higher than 4.5 kHz this period will be shorter.

210 Warning: Low Frequency (LO FREQ. W)

Value:

0 to 500 Hz ★ 120 Hz

Function:

Set the low frequency (f_{LOW}) at which the warning is to occur.

Description:

If the output frequency falls below the frequency set (f_{LOW}), the display shows LO FREQ. WARN.

You can also choose to program the signal outputs in parameters 408 and 409 to give a signal.

211 Warning: High Frequency (HI FREQ. W)

Value:

0 to 500 Hz ★ 120 Hz

Function:

Set the high frequency (f_{HIGH}) at which the warning is to occur.

Description:

If the output frequency increases above the frequency set (f_{HIGH}), the display will read HI FREQ. WARN.

You can also choose to program the signal outputs in parameters 408 and 409 to give a signal.

213 Warning: High Current (HI CURR. W)

Value:

 0.0 to $I_{VLT,MAX}$ ★ $I_{VLT,MAX}$

Function:

Set the current (I_{HIGH}) at which the warning is to occur.

Description of choice:

If the motor current rises above the I_{HIGH} programmed, the display will read HI CURR. WARN.

You can also choose to program the signal outputs in parameters 408 and 409 to give a signal.

215 Accel (ramp-up) Time (RAMP UP TI)

Value:

0.1 to 800 sec. ★ 5 s

Function:

Using this parameter you can record the required acceleration time from 0.1 Hz to the rated output frequency (parameter 105).

Description:

To ensure the fastest possible start, choose a value for the ramp-up time so that the current limit is not activated. The ramp-up time is always defined as the acceleration time from 0 Hz to the rated motor frequency.

216 Decel (ramp-down) Time (RAMP DOWN)

Value:

0.1 to 800 sec. ★ 5 s

Function:

Using this parameter you can record the required deceleration time from rated output frequency to 0 Hz.

Description:

The ramp-down time can be selected in the range 0.1-800 seconds. If the ramp-down time is too short the VLT's voltage limit becomes active, which will extend the ramp-down time. Short ramp-down times will require a VLT unit with a brake function and installation of a brake resistor. The ramp-down time is always defined as the deceleration time from the rated motor frequency to 0 Hz.

218 Quick Stop Ramp (QUICK STOP RAMP)

Value:

0.1 - 800 sec. ★ 1 s

Function:

Using this parameter you can choose an alternative deceleration ramp - a programmable quick stop ramp.

Description of choice:

The ramp-down time can be selected in the range 0.1 - 800 seconds, calculated from the rated frequency to 0 Hz. If the ramp-down time is too short the VLT's voltage limit becomes active, which will extend the ramp-down time. Short ramp-down times will require a VLT unit with a brake function and installation of a brake resistor.

224 Carrier Frequency (CARRIER FR)

Value:

2.0 to 14.0 kHz ★ 4.5 kHz

Function:

The set value determines the carrier frequency of the inverter. Changing the carrier frequency may minimize acoustic noise from the motor.

Description:

It is possible to change the carrier frequency between 2 and 14 kHz. The disadvantages of operating at a high carrier frequency are:

- reduced continuous output current
- reduced efficiency
- higher capacitive leakage current
- increased RFI radiation from the VLT

230 Digital Speed Up/Down (DIG. SPEED UP/DOWN)

Value:

- ★ Disable (DISABLE) [0]
- Enable (ENABLE) [1]
- Enable and Save (ENABLE and SAVE) [2]

Function:

Using this parameter you can make the VLT adjustable frequency drive lock the output frequency to the latest indicated speed reference.

Description:

You can choose to have either digital speed up/down (terminal 18/27 and 19) or other speed references. When you have chosen *Enable* you must choose *Speed Up* (terminal 18) and *Speed Down* (terminal 19) in parameters 402/404 and 403.

When Enable and Save is selected a speed will be saved automatically after new start-up.

The other references will not be active so that the digital references cannot be combined with other references.

★ = ROM default setting. Text in () = display text. Figures in [] are used when communicating with the bus.

Group 3 -- Functions and Timers

300 Brake Function (START FREQ)

Value:

- ★ Not Applied (NOT APPLIED) [0]
- Applied (APPLIED) [1]

Function:

Using this parameter you can inform the VLT adjustable frequency drive that a brake function and a brake resistor have been connected.

Description:

Choose Applied if you use a brake function and a brake resistor.

306 DC Braking Time (DC-BRAKE T)

Value:

- 0 to 60 sec. ★ 0 sec.

Function:

Using this parameter you can record how long the DC braking must be active

Description:

When you choose the braking time you must consider if you want to maintain the braking torque or if you want to use a stop function.

The DC braking time must be ≠ 0 to activate DC braking.

307 DC Brake Cut-in Frequency (DC-BRK ON)

Value:

- 0 to 500 Hz ★ 1 Hz.

Function:

Using this parameter you can record the output frequency at which DC braking must start when ramping down to standstill.

Description:

The cut-in frequency depends on the application. The cut-in frequency must be ≠ 0 to activate DC braking. Instead of using this parameter you can activate DC braking via terminal 27 if a DC braking time and a DC brake voltage have been recorded.

308 DC Brake Voltage (DC-BRK VOL)

Value:

- 0 to 50 V ★ 10 V

Function:

Using this parameter you can record the DC brake voltage for the motor.

Description:

The size of the voltage depends on the motor size. The bigger the motor the lower the DC brake voltage.



WARNING: At frequent DC-braking the DC brake voltage should not be too high. This is to avoid motor overload. The DC brake voltage must be ≠ 0 to activate DC braking.

309 Reset Function (RESET MODE)

Value:

- ★ Manual reset (MANUAL) [0]
- Automatic reset 1 (AUTO 1) [1]
- Automatic reset 5 (AUTO 5) [5]

Function:

Using this parameter you can choose how you want to reset an alarm

Description:

If you choose *Manual Reset* you must reset the VLT adjustable frequency drive via the keyboard or via terminals 19, 27, or 29. The display shows TRIP.

If you choose *Auto Reset 1* the VLT will automatically try to reset once after alarm. The display shows AUTO START.

As long as the display shows AUTOSTART the unit will try to reset every 20 minutes.

If you choose *Auto Reset 5* the VLT will automatically try to reset 5 times after alarm. The display shows AUTO START.



WARNING: The motor may start without warning.

310 Trip Delay at Current Limit (TRIP DLY@C)

Value:

0 to 60 secs.

★ Infinite at 61

Function:

Using this parameter you can record how long the current limit may be active before trip.

Description:

Record the delay time.



WARNING: If you choose Infinite, and your load is between 105% and 160%, trip may occur after a given interval.

315 Motor Thermal Protection (MOTOR THER)

Value:

- ★ Off (PROTECT-OFF) [0]
- Only Warning (ONLY WARNING) [1]
- Trip (TRIP) [2]

Function:

The VLT adjustable frequency drive calculates whether the motor temperature exceeds the permissible limits. The calculation is based on 1.16 x rated motor current, as set in parameter 107.

Description:

Select *Off* (OFF) if no warning or tripping is required.
 Select *Warning* if only a warning is to be displayed when the motor is overloaded. The drive can be programmed to give an external warning through the signal outputs set by parameters 408 through 409.
 Select *Trip* if you want warning and trip to be displayed.

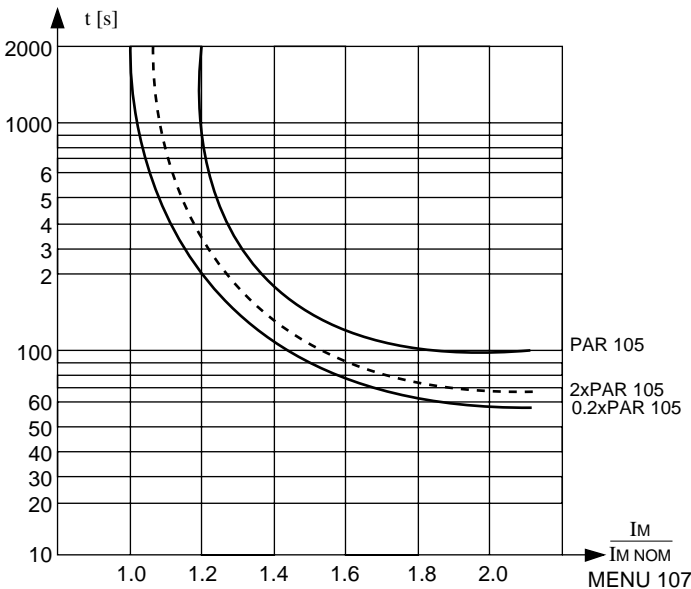

★ = ROM default setting. Text in () = display text. Figures in [] are used when communicating with the bus.

Group 4 -- Inputs and Outputs
402 Terminal 18 (TERMINAL 18 START)

Value:

★ Start (START)	[0]
Pulse Start (PRESS CONT.)	[1]
No Function (NO FUNCTION)	[2]
Speed Up (SPEED UP)	[3]
Digital Reference Select (SPEED SELECT)	[4]
Reversing (REVERSING)	[5]
Reset and Start (RESET&START)	[6]
Motor Coasting & Start (COASTING/START)	[7]

Function:

This parameter gives the motor various start signals.

Description:

 [0] *Start* :

24 V on terminal 18 will make the motor ramp up to the set reference. 0 V will make the motor ramp down to stop.

 [1] *Pulse Start*:

On selection of Press Cont. in parameter 402 and application of a pulse (24 V) to terminal 18, the motor will ramp up to the set reference. Further pulses do not have any effect. (Therefore the motor must be stopped via terminal 27 (parameter 404).

 [2] *No Function*:

Locks the input.

 [3] *Speed Up* :

 This is used together with parameter 230. It is possible to make the output frequency increase towards f_{MAX} as long as 24 V is applied to terminal 18.

At 0 V on terminal 18 the output frequency is maintained.

Also refer to parameter 403).

 [4] *Digital Reference Select*:

Together with parameter 403 you can choose between four different digital references:

Terminal 18/27	Terminal 19	
0	0	Digital reference 1
1	0	Digital reference 2
0	1	Digital reference 3
1	1	Digital reference 4

 [5] *Reversing*:

If the motor reverses when 24 V is applied to terminal 18, it will change direction again when 0 V is applied.

 [6] *Reset and Start*:

The function can be used as start when terminals 27 and 19 are used to select between the digital references and terminal 29 to change setup (8 digital speeds). 24 V applied to terminal 18 resets the VLT adjustable frequency drive and the motor ramps up to the set reference according to the ramp-up time set in parameter 215.

 [7] *Motor Coasting and Start* :

24 V applied to terminal 18 makes the motor ramp up to the set reference..

0 V applied to terminal 18 sets the motor coasting, running freely until it stops. This can be used in connection with a mechanical brake.

403 Terminal 19 Reversing (TERM 19 REVERSING)

Value:

★ Reversing (REVERSING)	[0]
Start Reversing (START REV)	[1]
No Function (NO FUNCTION)	[2]
Speed Down (SPEED DOWN)	[3]
Digital Reference Select (SPEED SELECT)	[4]
Reset (RESET)	[5]

Function:

Using this parameter (terminal 19) you can e.g. change the motor's direction.

Description:

 [0] *Reversing*:

Reverses the motor, when 24 V is applied to terminal 19 and changes the rotation direction again when 0 V is applied to the terminal.

 [1] *Start Reversing*:

Reverses the motor, when 24 V is applied to terminal 19. The motor stops when 0 V is applied to the terminal.

 [2] *No Function*:

Locks the input.

 [3] *Speed Down*:

 This is used together with parameter 230. It is possible to make the output frequency drop towards f_{MIN} , as long as 24 V is applied to terminal 19.

At 0 V applied to terminal 19, the output frequency in question is maintained. Also refer to parameter 402.

 [4] *Digital Reference Select*:

Together with parameter 402 you can choose between four different digital references:

Terminal 18/27	Terminal 19	
0	0	Digital reference 1
1	0	Digital reference 2
0	1	Digital reference 3
1	1	Digital reference 4

 [5] *Reset*:

In case of alarm the VLT can be reset by applying 24 V to terminal 19.

404 Terminal 27 Stop (INPUT 27)

Value:	
Motor Coasting Stop (MTR. COAST)	[0]
Quick-Stop (Q-STOP)	[1]
DC Braking (DC-BRAKE)	[2]
★ Reset and Motor Coasting (RST & COAST)	[3]
Stop (STOP=PRESS)	[4]
Reset and Start (RST & START)	[5]
Speed Down (SPEED DOWN)	[6]
Digital Reference Select (SPEED SELECT)	[7]

Function:

Using this parameter (terminal 27) you can give the motor various stop signals.

Description:

- [0] *Motor coasting stop:*
If 0 V is applied to terminal 27 the motor will coast to a stop.
 - [1] *Quick Stop:*
If 0 V is applied to terminal 27 the motor will brake to a stop according to the ramp-down time set in parameter 218. A DC current brakes the motor after ramping down to 0, according to the setting of parameters 306-308.
 - [2] *DC Brake:*
If 0 V is applied to terminal 27 the motor will brake to a stop according to the settings of parameters 306 and 308.
 - [3] *Reset and Motor Coasting:*
If 0 V is applied to terminal 27 the motor will start coasting and the VLT adjustable frequency drive is reset.
 - [4] *Stop = Press:*
A circuit breaker between terminals 12 and 27, when opened briefly causes ramp-down to stop.
 - [5] *Reset and Start:*
This can be used as a start function when you use terminals 18 and 19 to select a digital reference. 24 V applied to terminal 27 will make the adjustable frequency drive reset and the motor ramp up to the set reference according to the ramp-up time set in parameter 215.
 - [6] *Speed Down:*
This is used together with parameter 230. It is possible to make the output frequency drop towards f_{MIN} , as long as 24 V is applied to terminal 27. At 0 V applied to terminal 27, the output frequency in question is maintained. Also refer to parameter 402.
 - [7] *Digital Reference Select:*
Together with parameter 402 you can choose between four different digital references:
- | | | |
|----------------|-------------|---------------------|
| Terminal 18/27 | Terminal 19 | |
| 0 | 0 | Digital reference 1 |
| 1 | 0 | Digital reference 2 |
| 0 | 1 | Digital reference 3 |
| 1 | 1 | Digital reference 4 |

405 Terminal 29 Jog (TERMINAL 29 JOG)

Value:	
★ Jog (JOG)	[0]
Start (START)	[1]
Digital Reference (DIGITAL REF.)	[2]
Pulse Input, 100 Hz (PULSES 100 Hz)	[3]
Pulse Input, 1 KHz (PULSES 1 KHz)	[4]
Pulse Input, 10 KHz (PULSES 10 KHz)	[5]
Setup Select (SETUP SELECT)	[6]
Reset (RESET)	[7]
Reversing (REVERSING)	[8]
Speed Down (SPEED DOWN)	[9]

Function:

Using this parameter (terminal 29) you can give the motor different jog signals.

Description:

You can set the output frequency to a pre-programmed value (jog in parameter 203). Recording Digital reference you can enable/disable values stored in parameters 205-208. If terminal 29 is used for either pulse signal reference (open loop) or pulse signal feedback (closed loop) choose one of the pulse inputs [3] - [5]. If Multi Setup is selected in parameter 001, the terminal can be used to switch between setups 1 and 2.

★ = ROM default setting. Text in () = display text. Figures in [] are used when communicating with the bus.

408 Terminal 46 Output (TERMINAL 46 OUTPUT)

Value:

Unit Ready (UNIT READY)	[0]
★ Unit Ready Remote Control (UNT RDY RCTL)	[1]
Enabled not Warning (ENABLED no WR)	[2]
Running (RUNNING)	[3]
Running, no warning (RUNNING noWR)	[4]
Running in range, no warning (RUNinRANGE)	[5]
Speed = reference, no warning (RUN@REF noWR)	[6]
Alarm (ALARM)	[7]
Alarm or warning (ALARM or WARN)	[8]
Current limit (CURRENT LIMIT)	[9]
Out of frequency range (OUT FREQ RGE)	[10]
Out of current range (OUT CURR RGE)	[11]
Reversing (REVERSING)	[12]
Pulse output 15 Hz - 1.5 kHz (PULSEOUT 1500)	[13]
Pulse output 15 Hz - 3.0 kHz (PULSEOUT 3000)	[14]
Pulse output 15 Hz - value par. 005 (PULSPAR005)	[15]
Send/receive RS485 (CTS/RTS-RS485)	[18]
Receive/send RS485 (CTS/RTS-RS485)	[19]

Function:

Using this parameter you can choose between different output signals. The output is an open collector output and therefore a pull-up resistor must be connected to terminal 12 (+24 V).

Description:

For the pulse output the lowest output frequency is 15 Hz and the highest output frequency is 5 Hz.
RS 485 send/receive control is used when the serial port is connected to the RS 485 network via a RS 232/RS 485 adapter.

Connection example where the signal is active high:

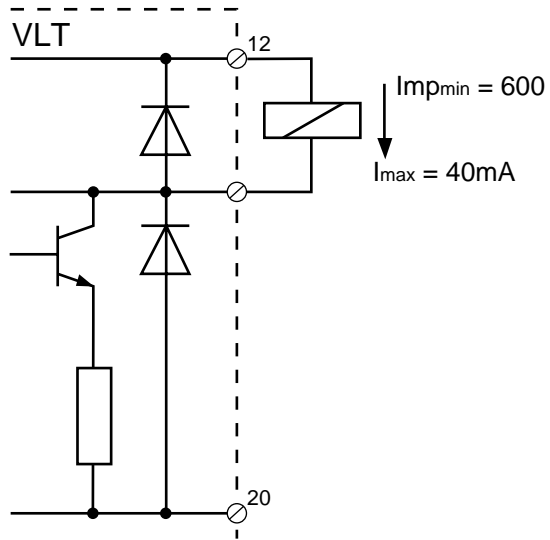

Connection example where the signal is active low:

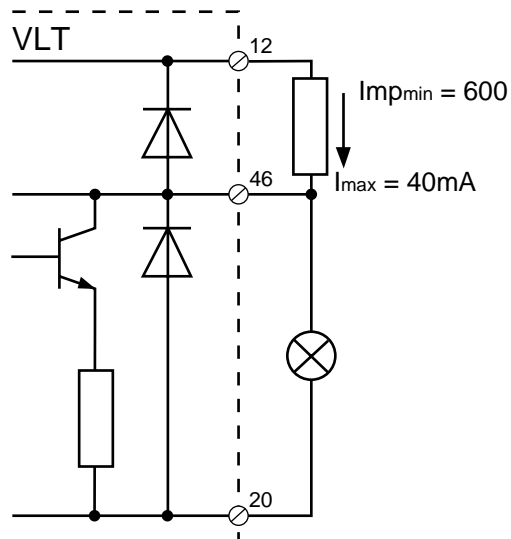

Connection example using RS 232/485 adapter:

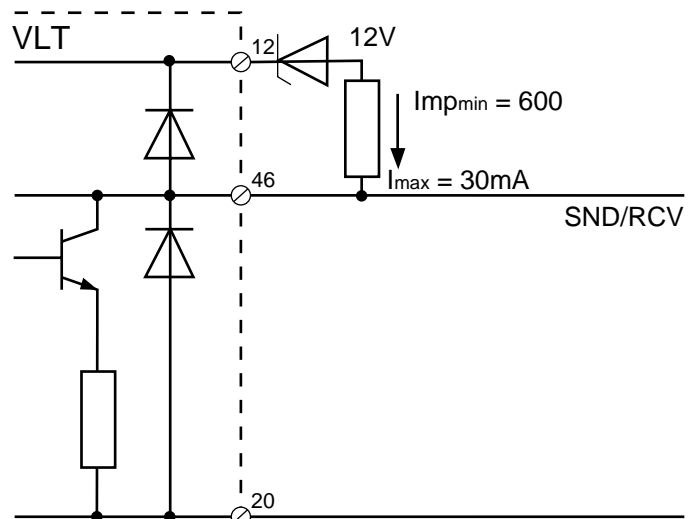

★ = ROM default setting. Text in () = display text. Figures in [] are used when communicating with the bus.

409 Terminal 01 Relay Output (RELAY 01)

Value:

★ Unit ready (UNIT READY)	[0]
Unit ready - remote control (UNT RDY RCTL)	[1]
Enabled no warning (ENABLED noWR)	[2]
Running (RUNNING)	[3]
Running, no warning (RUNNING noWR)	[4]
Running in range, no warning (RUNinRANGE)	[5]
Running on reference, no warn (RUN@REF noWR)	[6]
Alarm (ALARM)	[7]
Alarm or warning (ALARM or WARN)	[8]
Current limit (CURRENT LIMIT)	[9]
Out of frequency range (OUT FREQ RGE)	[10]
Out of current range (OUT CURR RGE)	[11]
Reversing (REVERSING)	[12]

Description:
 You can use the relay output 01 to indicate selected status and warnings. The relay is activated when the conditions for the selected data values are fulfilled.
 When relay output 01 is not active, there is no connection between terminal 01 and 02. The relay output is potential-free and the maximum load is 2 A at 24 VDC or 250 VAC.

411 Analog Input Current (ANALOG REFTYPE)

Value:

★ Linear between minimum and maximum (LINEAR)	[0]
Proportional with lower limit (PROP W/LIMIT)	[1]

Function:
 Is used to determine which frequency converter is to follow an analog reference signal.

Description:
 When you select [1] the reference signal will not affect the output frequency until it reaches a value equivalent to the set minimum frequency (parameter 201).

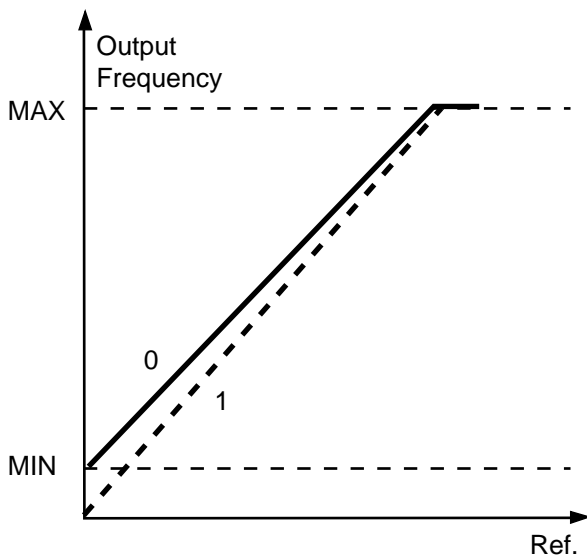

★ = ROM default setting. Text in () = display text. Figures in [] are used when communicating with the bus.

412 Terminal 53 Analog Input Voltage (INPUT #53)

Value:

No Function (NO FUNCTION)	[0]
★ 0 to 10 V (0 to 10 V DC)	[1]
10 to 0 V (10 to 0 V DC)	[2]

Description:
 Record the polarity of analog control signals to inputs 53 and 60. You can choose between voltage, current and polarity.
 If you use both inputs for reference signals the total reference signal will be a summation.

413 Terminal 60 Analog Input Current (INPUT #60)

Value:

No Function (NO FUNCTION)	[0]
★ 0 to 20 mA (0 to 20 mA)	[1]
4 to 20 mA (4 to 20 mA)	[2]
20 to 0 mA (20 to 0 mA)	[3]
20 to 4 mA (20 to 4 mA)	[4]

Description:
 If you are using a PI controller one of the inputs or the pulse input must be used for the feedback signal.
 If you are using current control, one of the inputs must be used to set a current limit.
 Naturally these choices block the same type of reference signal.

Group 5 -- Serial Data Interface

500 Address (ADDRESS)

Value:

01 to 99	(echo)
101 to 199	★ 01

Function:

Using this parameter you set the bus address for each VLT via the control panel. However, the first telegram after the voltage connection can change the bus address. This means that address change from the bus is no longer possible. The echo function enables connection of several VLT 2000 adjustable frequency drives to the same PC.

Description:

Specify an address of each unit connected. If the PC/PLC addresses 00, all drives connected will be written to at the same time. The units in this case not give a reply to the master.

address change via bus enables address change on units without display.

The echo function is active on address 101-199, shown as 01-99 ECHO. The ring is built up by connecting Tx on the first VLT to Rx on the next VLT.

The last unit's Tx is connected to Rx on the PC. Terminal 20 (frame) must be connected throughout, but with the PC connected at only one end.

501 Bits/Sec. Baud Rate (BAUD RATE)

Value:

300, 600, 1200	★1200
----------------	-------

Function:

Using this parameter you can set the speed at which a character is transmitted via the RS 232 port. It is defined as the number of bits transmitted per second.

Description:

The transmission rate of the VLT must be set in accordance with the transmission rate of the PLC/PC applied. The transmission rate can only be altered via the control panel.

502 Data Readout (DATA READO)

Value:

- ★ [0] Reference (REFERENCE %) %
- [1] Frequency (FREQUENCY Hz) Hz
- [2] Display/Feedback (FDBK UNIT) "unit"
- [3] Current (CURRENT A) A
- [4] Torque (TORQUE %) %
- [5] Power (POWER kW) kW
- [8] Motor voltage (OUTPUT VOLT.V) V
- [9] DC voltage (DC BUS V) V
- [10] Motor thermal load (ETR (MOT) %) %
- [11] Thermal inverter load (ETR (VLT) %) %
- [12] Digital input (DIG IN CODE) binary code
- [13] Analog input 1 (ANALOG IN 53) in terminal 53
- [14] Analog input 2 (ANALOG IN 60) in terminal 60
- [15] Warning parameter (WARN CODE) binary code
- [16] Control word (CONTROL WORD)
- [17] Status word (STATUS WORD)
- [18] Alarm parameter (ALARM CODE) binary code
- [19] Software version no. 4 digits

Description:

NOTE: Menu 502 can only be selected from the bus. These values are read-only values. The PC/PLC may prompt for a value from an index between 0 and 19.

502 Data Read-Out (DATA READOUT) continued

[15] Warning parameter messages:

Frequency low re; parameter 210	value: 32768
Frequency high re; parameter 211	value: 16384
Current limit, re; power section	value: 8192
Key blocked	value: 2048
Motor overload	value: 1024
Inverter overload	value: 512
Outside frequency range	value: 256
Current higher than par. 213	value: 128
Data locked	value: 64
Read only	value: 32
Current limit re; control card	value: 16
Overvoltage	value: 8
Undervoltage	value: 4
Can only be changed in stop mode	value: 2
Parameter limit	value: 1

Usually only one warning occurs at a time, so one of the figures in parameter 502, index 15, will show. In the event of several simultaneous warnings, e.g. Motor overload and Current limit, re; control card, the two values are added;

Motor overload:	512
Current limit re; control card:	<u>+ 16</u>
Reading in par. 502, index 15:	528

[16] Alarm parameter messages:

Excess temperature, re; power section	value: 16384
Ground connection	value: 4096
Overvoltage	value: 1024
Undervoltage	value: 512
Unspecified inverter fault	value: 236
Inverter overload	value: 128
Motor overload	value: 64
Short circuit	value: 16
VLT attempts restart	value: 8
Overcurrent	value: 4
Trip locked	value: 1

In contrast to warnings, alarms will always be combined, i.e. at least 2 of the alarm parameters apply, e.g.

Unspecified inverter fault will usually occur with another alarm, e.g. Inverter overload. It will give the following reading:

Unspecified inverter fault:	256
Inverter overload:	<u>+ 128</u>
Reading in par. 502, index 18:	384

In case of Short circuit Ground connection and Excess temperature, re; power section, Trip locked will also occur.

This will give a typical reading:

Ground connection:	4096
Unspecified inverter fault:	256
Trip locked	<u>+ 1</u>
Reading in par. 502, index 18:	4353

503 Coasting (COAST)

Value:

Digital (DIGITAL)	[0]
Bus (BUS)	[1]
Logical and (AND)	[2]
★ Logical or (OR)	[3]

Description:

In parameters 503 to 510 you can choose to control the VLT adjustable frequency drive via the control unit's terminals (digitally) and or via the bus.

When using *Logical* and *Bus* values in parameters 503-510, the digital control terminals are either dependent on or overruled by the bus commands.

504 Quick-Stop (Q-STOP)

Value:

Digital (DIGITAL)	[0]
Bus (BUS)	[1]
Logical and (AND)	[2]
★ Logical or (OR)	[3]

Description:

In parameters 503 to 510 you can choose to control the VLT adjustable frequency drive via the control unit's terminals (digitally) and or via the bus.

When using *Logical* and *Bus* values in parameters 503-510, the digital control terminals are either dependent on or overruled by the bus commands.

505 DC Brake (DC-BRAKE)

Value:

Digital (DIGITAL)	[0]
Bus (BUS)	[1]
Logical and (AND)	[2]
★ Logical or (OR)	[3]

Description:

In parameters 503 to 510 you can choose to control the VLT adjustable frequency drive via the control unit's terminals (digitally) and or via the bus.

When using *Logical* and *Bus* values in parameters 503-510, the digital control terminals are either dependent on or overruled by the bus commands.

506 Start (START)

Value:

Digital (DIGITAL)	[0]
Bus (BUS)	[1]
Logical and (AND)	[2]
★ Logical or (OR)	[3]

Description:

In parameters 503 to 510 you can choose to control the VLT adjustable frequency drive via the control unit's terminals (digitally) and or via the bus.

★ = ROM default setting. Text in () = display text. Figures in [] are used when communicating with the bus.

Group 5 -- Serial Data Interface

Using the serial RS 232 port (terminals 71 and 72) you can read and set parameters of the VLT adjustable frequency drive and issue reference and control commands. The serial port can be used for point to point communication between the VLT and a PC. Communication takes place by means of a protocol specified by Danfoss, and using the echo function (parameter 500) you can connect several VLT adjustable frequency drives.

The data format consists of 10 bits:

- One start bit (logical 0)
- Eight data bits
- One stop bit (logical 1)

Set the baud rate (rate of transmission) in parameter 501 and the address of each unit in parameter 500.

Protocol:

The communication protocol for the VLT Series 2000 consists of 22 ASCII characters make it possible to operate, set and read parameters, and to receive status feedback from the VLT adjustable frequency drive.

The communication takes place in the following way:

The master sends a telegram to a VLT adjustable frequency drive. Then the master awaits a reply from the VLT before sending a new message. The reply to the master resembles the telegram sent by the master, but now contains any updated data values and the status of the VLT.

Data format

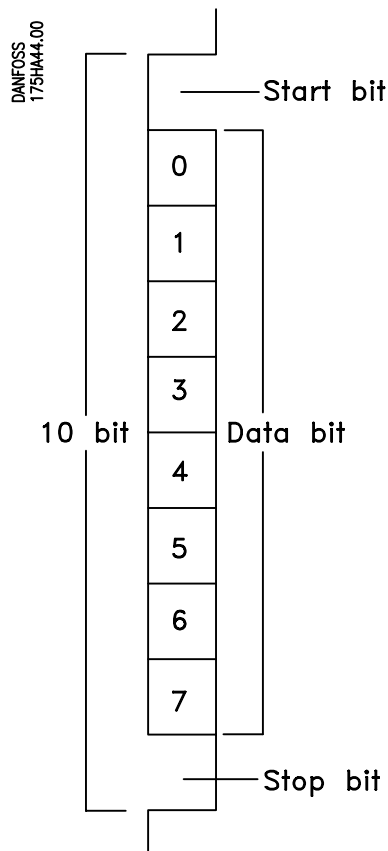

Telegram format

Function	byte #	ASCII
Start byte	1	<
Address	2	
	3	
	4	
Control char. Control/status word	5	
	6	
	7	
	8	
Parameter #	9	
	10	
	11	
	12	
	13	
Sign Data	14	
	15	
	16	
	17	
	18	
	19	
Comma Check sum	20	
	21	
Stop byte	22	>

DANFOSS
175HA043.11

Byte 1:

Start byte, which in this case must be the character "<" (ASCII: 60).

Byte 2 and 3:

The two-digit address of the adjustable frequency drive. This address is also programmed in parameter 500. Sending to address 00 means transmission to all units connected to the bus. None of the units will reply, but they will carry out the command.

Byte 4:

Control parameter telling the drive what to do with the following data values.

U (update)

Means that the data value, bytes (14-18), must be read into the drive.

R (read)

Means that the master wishes to read the data value of the parameter in bytes 9 through 12.

C (control)

Means that the drive reads only the four command bytes, 5 through 8, and returns with status. Parameter number and data value are ignored.

I (read index)

Means that the drive reads the index and parameter and returns with status. The parameter is stated in bytes 9 through 12 and index is stated in bytes 13 through 18. Parameters with indices are read-only parameters. Action will be taken on the control word.

Byte 5 through 8:

Control and status words, used to send commands to the frequency converter and to send status from the frequency converter to the master.

Byte 9 through 12:

The parameter number is inserted in these bytes.

Byte 13:

Used for the sign before data value in bytes 14 through 18. All characters other than "-" are taken as "+".

Byte 14 through 18:

Here is placed the data value of the parameter stated in bytes 9 through 12. The value must be a whole number. If a decimal point is needed, it is stated in byte 19.

**NOTE:**

Some data values have brackets with a number, for example "[0]". Use this number instead of the "Text" data value.

Byte 19:

The position of the decimal point in the data value stated in bytes 14-18. The number states the number of characters after the decimal point. Consequently, byte 19 can be 0, 1, 2, 3, 4 or 5. For example, the number 23.75 is stated:

Byte no.	13	14	15	16	17	18	19
in ASCII character	+	2	3	7	5	0	3

If byte 19 = 9, this indicates an unknown parameter.

Byte 20 and 21:

Used for summary control. If there is to be no control, the function can be cancelled by means of the "?" character (ASCII: 63) in the two bytes.

Byte 22:

Stop byte, stating the end of the telegram. The character ">" is used (ASCII: 62).

VLT Status

The four control and status bytes are used to send control commands to the adjustable frequency drive when the telegram is sent from the master and to send status from the VLT to the master when the telegram is returned from the VLT adjustable frequency drive. The four bytes operate as status from the VLT with the following functions:

		Status word															
		Byte 8				Byte 7				Byte 6				Byte 5			
		T I M E R S	C U R R E N T	V O L T A G E	V L T O K	D O E S N O T	O U T O F	L O C A L O P E R A T E	S P E E D ≠	N O W A R N I N G	S T A R T	O N	O N	N O	C O A S T	V L T	C O N T R O L S
ASCII	0 / 1	OK / OVERSHOOT	OK / OVERSHOOT	OK / OVERSHOOT	/ STALLS	RUN / RUNS	OPERATING	OPERATING	OPERATING	OPERATING	OPERATING	OPERATING	OPERATING	OPERATING	OPERATING	OPERATING	OPERATING
		15	14	13	12	11	10	09	08	07	06	05	04	03	02	01	00
@		0	0	0	0	0	0	0	0	0	0	0	0	0	0	0	0
A		0	0	0	1	0	0	0	1	0	0	0	1	0	0	0	1
B		0	0	1	0	0	0	1	0	0	0	1	0	0	0	1	0
C		0	0	1	1	0	0	1	1	0	0	1	1	0	0	1	1
D		0	1	0	0	0	1	0	0	0	1	0	0	0	1	0	0
E		0	1	0	1	0	1	0	1	0	1	0	1	0	1	0	1
F		0	1	1	0	0	1	1	0	0	1	1	0	0	1	1	0
G		0	1	1	1	0	1	1	1	0	1	1	1	0	1	1	1
H		1	0	0	0	1	0	0	0	1	0	0	0	1	0	0	0
I		1	0	0	1	1	0	0	1	1	0	0	1	1	0	0	1
J		1	0	1	0	1	0	1	0	1	0	1	0	1	0	1	0
K		1	0	1	1	1	0	1	1	1	0	1	1	1	0	1	1
L		1	1	0	0	1	1	0	0	1	1	0	0	1	1	0	0
M		1	1	0	1	1	1	0	1	1	1	0	1	1	1	0	1
N		1	1	1	0	1	1	1	0	1	1	1	0	1	1	1	0
O		1	1	1	1	1	1	1	1	1	1	1	1	1	1	1	1

NOTE: Each byte consists of 8 bits, but the frequency converter uses only the last 4 bits.

VLT Control Commands

The four control and status bytes are used to send control commands to the VLT adjustable frequency drive when the telegram is sent from the master, and to send status from the VLT to the master when the telegram is returned from the VLT. When these four bytes are used for control, they have the following meaning:

- OFF 1: Makes a normal ramp stop of the motor and opens the relay output of the VLT (relay off).
- OFF 2: Makes a motor coast and opens the relay output (relay off)
- OFF 3: Same as OFF 1, but the motor makes a quick-stop.
- Bit 10: This bit has to be 1, if any of the control commands should cause a reaction.

		CONTROL WORD															
		Byte 8				Byte 7				Byte 6				Byte 5			
		N O F U N C T I O N / R E V E R S I N G	C H O I C E O F S E T - U P 2	C H O I C E O F S E T - U P 1	N O F U N C T I O N / C A T C H - U P	N O F U N C T I O N / S L O W D O W N	D A T A / N O T V A L I D / V A L I D	J O G / O F F / O N	J O G / O F F / O N	N O F U N C T I O N / R E S E T	R A M P / S T O P / S T A R T	H O L D / R A M P / E N A B L E D	Q U I C K - S T O P / R A M P	C O A S T / E N A B L E D	O F F / O N / 3	O F F / O N / 2	O F F / O N / 1
15	14	13	12	11	10	09	08	07	06	05	04	03	02	01	00		
@	0	0	0	0	0	0	0	0	0	0	0	0	0	0	0	0	
A	0	0	0	1	0	0	0	1	0	0	0	1	0	0	0	1	
B	0	0	1	0	0	0	1	0	0	0	1	0	0	0	1	0	
C	0	0	1	1	0	0	1	1	0	0	1	1	0	0	1	1	
D	0	1	0	0	0	1	0	0	0	1	0	0	1	0	0	1	
E	0	1	0	1	0	1	0	1	0	1	0	1	0	1	0	1	
F	0	1	1	0	0	1	1	0	1	1	0	0	1	1	1	0	
G	0	1	1	1	0	1	1	1	1	1	1	0	0	1	1	1	
H	1	0	0	0	1	0	0	0	1	0	0	1	1	0	0	0	
I	1	0	0	1	1	0	0	1	1	0	0	1	1	0	0	1	
J	1	0	1	0	1	0	1	0	1	0	1	0	1	0	1	0	
K	1	0	1	1	1	0	1	1	1	0	1	1	0	1	1	1	
L	1	1	0	0	1	1	0	0	1	1	0	1	1	1	0	0	
M	1	1	0	1	1	1	0	1	1	1	0	1	1	1	0	1	
N	1	1	1	0	1	1	1	0	1	1	1	0	1	1	1	0	
O	1	1	1	1	1	1	1	1	1	1	1	1	1	1	1	1	
P	1	1	1	1	1	1	1	1	1	1	1	1	1	1	1	1	

NOTE: Each byte consists of 8 bits, but the frequency converter uses only the last 4 bits.

Group 600 -- Service and Diagnostics

606 Total Operation Hours (TOTAL OP HRS)

Description:

See parameter 610.

607 Running Hours (RUNNING HRS)

Description:

See parameter 610.

608 Number of Power-ups (NO POWER)

Description:

See parameter 610.

609 Number of Over-temperature (NO OVERTE)

Description:

See parameter 610.

610 Number of Over-voltage (NO OVERVO)

Description:

Information stored by the VLT adjustable frequency drive for later analysis.

Parameter 606-607 are only updated every hour.

Status Messages

UNIT READY (LOCAL)

Control card and power section are powered up and OK.



When the adjustable frequency drive's output frequency is reduced more quickly than the motor speed (due to inertia) can be changed, the motor will act as a generator. It will send energy back to the VLT and as a result the intermediate circuit voltage will increase.

ENABLED STOP (LOCAL)

Unit ready and Q-stop signal active.

START (LOCAL)

Enabled and start signal applied, no or too low reference signal.

RUN OK (LOCAL)

Unit is running on reference.

JOGGING (LOCAL)

RAMPING (LOCAL)



If the warning OVERVOLTAGE is displayed when the speed is reduced, you can increase the ramp-down time. If that is not possible, it may be necessary to activate the dynamic brake function with brake resistor. If the warning occurs in other situations, the problem is due to the AC line.

Alarm Messages

The following alarm messages are displayed after the power section of the VLT adjustable frequency drive has been disconnected.

Messages	Caused by	Consequence	Reset
INVERTER FAULT	Unknown error (not one of those errors mentioned below)		Yes, possible
OVER VOLTAGE	a: Supply voltage too high b: Ramp-down time too short	a: Lower supply voltage b: Increase ramp down time or activate brake function to avoid overvoltage	Yes, possible
UNDER VOLTAGE	Supply voltage too low or loss of AC line phase		Yes, possible
OVER CURRENT	Motor current too high or wrong motor parameter setting	Check motor parameters Use a larger VLT	Yes, possible
GROUND FAULT	Short circuit between VLT power section and ground	Check installation and cable length	No, power off required
SHORT CIRCUIT	Short circuit between two motor phases	Check installation	No, power off required
OVER TEMP.	VLT temperature too high	Check installation	No, power off required
OVER LOAD	Load too heavy		Yes, possible after VLT thermal protection is lower than 100%
MOTOR TRIP	Motor protection		Yes, possible after VLT motor protection is zero

Warning Messages

Messages	Caused by	Consequence	Reset
CURRENT LIMIT	Over load	VLT decreases speed	--
VOLTAGE HIGH	Regenerative motor operation or supply voltage too high	The power section of the VLT stops within 5 sec.	--
VOLTAGE LOW	Missing phase or low supply	The power section of the VLT stops within 5 sec.	--
INVERTER TIME	Inverter overload	At 98.2% load VLT displays the following warning: "INVERTER TIME" At 100% load: "ALARM OVERLOAD"	--
MOTOR TIME	Motor overload VLT operates between 100% and	VLT operates at least 60 sec. *) depending on the value of the load before the power section of the VLT stops	--
LOW FRQ WARN	Output frequency lower than the value in parameter 210	Depending on application Warning only	--
HI FRQ WARN	Output frequency higher than the value in parameter 211	Depending on application Warning only	--
HI CUR WARN	Motor current higher than the value in parameter 213	Depending on application Warning only	--

*) The time is reduced at a higher switch frequency.

Reset Messages

Messages	Caused by	Consequence	Reset
AUTO START	VLT tripped	The VLT attempts to restart	--
TRIP	Fault condition of the VLT or the motor	The power section of the VLT stops	Yes
TRIP LOCKED	Fault condition (over temp., short circuit, ground fault) of the VLT	The power section of the VLT stops	No, power on Reset required

VLT 2000/2000 PACK, Motor Coil and Filter Options

	1Ø / 3Ø (1 x 220-240 V / 3 x 208-240 V)				3Ø (3 x 208-240 V)	
	VLT 2010	VLT 2015	VLT 2020	VLT 2030	VLT 2040	VLT 2050
EMC and motor coil module IP20 1-phase	195H6523	195H6524	195H6524	195H6525		
EMC and motor coil module IP20 3-phase	195H6522	195H6522	195H6522	195H6522		
EMC-filter module, IP20 (VGB-4)					195H6528	195H6528
Motor coil option, IP00	195H6510	195H6510	195H6510	195H6510		
Motor coil option, IP10 (VGB-4)	195H6521	195H6521	195H6521	195H6521		
LC and EMC filter module IP20 3-phase	195H6527	195H6526	195H6526	195H6526		
Motor coil module IP20	195H6529	195H6529	195H6529	195H6529		

	3Ø (3 x 380-460 V)				
	VLT 2020	VLT 2025	VLT 2030	VLT 2040	VLT 2050
EMC and motor coil module IP20, (380-415 V only)	195H6522	195H6522	195H6522	195H6522	195H6522
Motor coil option, IP10 (VGB-4)	195H6521	195H6521	195H6521	195H6521	195H6521
LC and EMC filter module IP20	195H6527	195H6527	195H6527	195H6526	195H6526
Motor coil module IP20	195H6529	195H6529	195H6529	195H6529	195H6529

195H6510, IP00

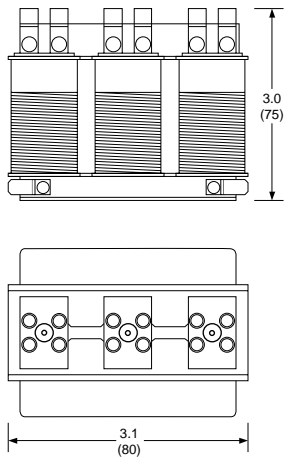

195H6522, 195H6523, 195H6524, 195H6525, 195H6526, 195H6527, 195H6528, 195H6529, IP20, Enclosure Module

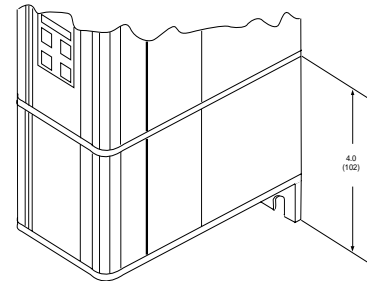

195H6521, IP10

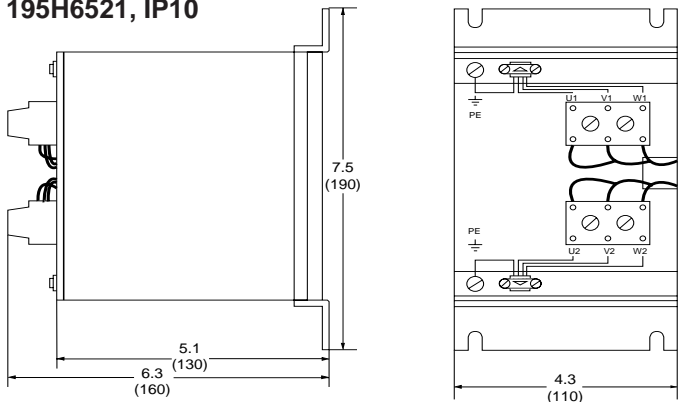

The following instructions will enable quick and easy set-up of the PI regulation and associated parameter settings. Detailed information about each parameter can be found in the parameter section of this manual.

Parameter 100:

Set the load type. There are several choices in each group but **variable torque medium** or **variable torque medium with AEO** will suit most pumps or fans.

Parameter 101:

Select **closed loop** operation.

Parameter 114:

Choose the type of **feedback signal** the transmitter is using. The default value is **current** as it is the most widely used signal type.

Parameter 115 & 116:

Are used to scale a display read-out which is proportional to the feedback transmitter signal. The value is displayed only if **feedback** has been selected in display mode. To get to display mode from any other mode press MENU & DATA keys simultaneously.

If a transmitter has a range of 0-5 bar, 0 can be set in parameter 115 and 5 in parameter 116. In parameter 117 the unit **bar** can be programmed.

The default values are 0 & 100, to display 0-100%.

Parameter 117:

Choose the unit of measurement for scaling the feedback signal of the transmitter set in parameter 115 & 116. The default value is %.

Parameter 119:

The feed forward factor allows a part of the set-point signal to by-pass the PID regulator. This gives faster response when starting up a system where the integration time (parameter 122) is very long, and the system error is small.

Set at 0%. Only add 5% at a time, and only if the system takes a long time to start up. The drawing shows the influence of the feed forward.

Parameter 120:

Controls the bandwidth of the output from PID controller. **Set at 100%.**

Parameter 121:

Controls the gain of the system. For most fan and pump systems it should not be higher than 0.9. If set to higher values the system may become unstable.

- **Centrifugal fans - between 0.1 - 0.6**
- **Centrifugal pumps - between 0.3 - 0.8**

Parameter 122:

Improves the final accuracy by integrating out the error.

- **Centrifugal fans - between 10-12 seconds**
- **Centrifugal pumps - between 3-8 seconds**

Parameter 123:

Differential time is not used in pump and fan systems.

Set to Off.

Parameter 124:

If the feedback signal is fluctuating it can be dampened with a time constant. This can occur on pump systems where the pipe can be shut off quickly and cause a standing wave of water.

Set initially to 0 seconds.

Parameter 125:

Leave at the default value of 100% unless the following conditions occur.

- If the feedback signal does not match the standard analog signal choices in parameter 412 & 413 a value must be programmed which scales the feedback signal to a standard analog value.
- When using min. speed, parameter 201, it must be ensured that the min. speed % value is not greater than the set-point % value, otherwise the min. speed will over-ride the set-point.

(See example on page 43.)

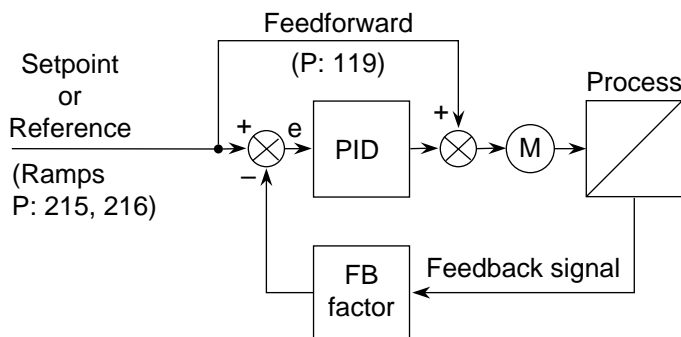

Example:

The set-point is 40%, and the min. speed is 50%.

1. Selecting a new set-point. Choose a value that will raise the set-point about 10% higher than the min. speed.
New set-point = % min. speed x 1.1 = 55%
2. Setting parameter 125. Apply the same increase to this parameter. $100 \times 1.1 = 110\%$

Parameter 201:

Set min. frequency if required.

If you enter a min. speed you must observe the following:

- When min. speed is used parameter 411 must be set to "proportional with min. limit".
- If the min. frequency % is higher than the set-point % you must re-scale parameter 125 and the set-point.

Parameter 202:

Max. frequency is normally set to 50 Hz. Running centrifugal pumps and fans above this speed will cause overload of the pump or fan, as the power increases to the third power of the speed change.

Example:

If the speed increased to 60 Hz the power will increase by a massive 173%.

Set at 50 Hz.

Parameter 205:

The internal set-point for the regulator.

Enter the set-point % value.

Externally it can be one of the choices of the analog values. Use of one of the analog choices will prevent its use as the feedback signal.

The use of the internal set-point reduces installation costs. Up to 4 internal set-points (by using parameters 205-208) can be selected by a combination of 2 switches. Refer to the instruction manual for further information.

The set-point can be found by calculating the percentage of required signal from the transmitter range.

Example:

A pressure transmitter has range of 0-10 bar. A set-point of 4 bar is required.

Set-point = $4/10 \times 100 = 40\%$

Enter 40 in parameter 205.

Parameter 214:

Use only linear ramps.

Parameter 215 & 216:

The ramps only function on starting and stopping the system.

Enter the ramp up and down times in seconds.

Parameter 315:

Set the motor thermal protection to **trip 1** if thermal protection of the motor is required.

Parameter 411:

This parameter must be changed from its default value when PID regulation is used.

Set to "proportional with min. limit".

Parameter 412-413:

Set the type of analog input signal for the set-point and feedback signals. Parameter 114 has previously set up the selection of the feedback signal type.

If parameter 205 (internal set-point) is used either current or voltage can be used as the feedback signal.

If one of the inputs is not used it must be set to no operation.

Normal or Inverse Control**Introduction:**

The control is called normal, if the motor speed is increased when the feedback signal goes down, and the motor speed is reduced if the feedback signal goes up. Typical for pump pressure systems and air handling units in variable air volume systems.

The control is called inverse if the motor speed is increased when the feedback signal is increased. Typical for pit pumping where: the faster the water flows into the pit, the faster the pump must pump out the water.

For inverse control; modification of the setpoint and feedback signal is required.

Example:

A transmitter has a 0-15 foot span equal to 0-20mA. The PID set-point must be set at 12 feet for inverse control.

- Enter 20-0 mA in parameter 413. The normal signal in figure A is converted to an inverse signal as shown in figure B.

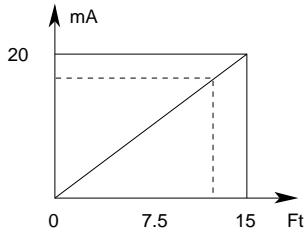

Figure A.

Normal signal from transmitter where 12 ft. represents 16mA (80%)

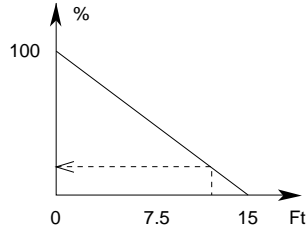

Figure B.

Inverted signal from par:413
12 ft. represents 100%-80%=20%

- Calculate the set point for inverse control.

$$\text{Setpoint} = 100 - (4/5 \times 100) = 20\%$$

It can be seen in figure C how the set point is calculated.

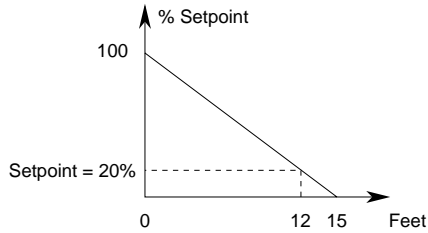

Figure C.

Inverted signal from par:413 (current)
where 12 ft. represents 100%-80%=20%

- If the internal set-point is used, ensure that parameter 412 (voltage input) is set to **no operation**.

- The values in parameter 115 & 116 must be reversed. The display at min. feedback in parameter 115 becomes display at max. feedback and parameter 116 becomes display at min. feedback.

- Connections and set-up are identical to normal control.

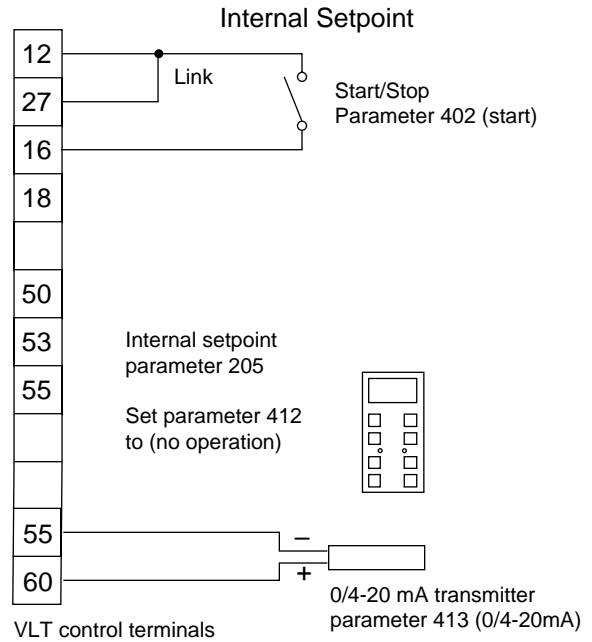
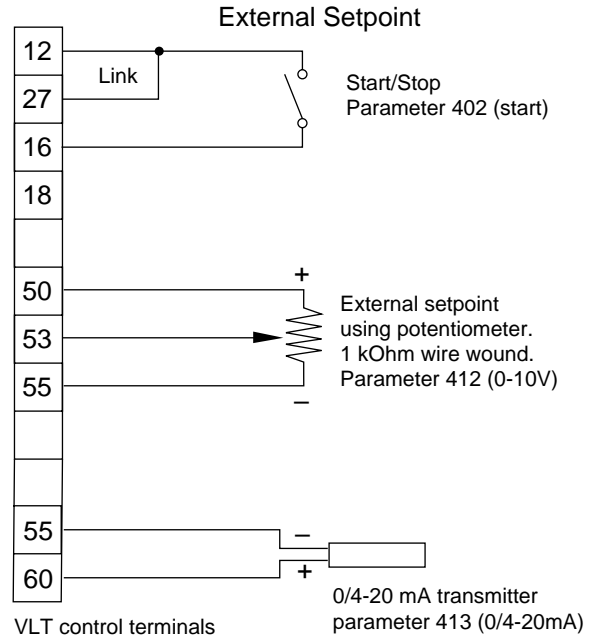

External Manual Control Over-ride

It is often necessary to run the machine manually for maintenance reasons.

Manual control can be carried out manually from the keypad of all the units.

If remote control of the manual over-ride is required additional circuitry is necessary.

For the VLT Series 3500 special parameters are available for external manual over-ride. Refer to the VLT Series 3500 instruction manual.

The following circuit and instructions for external manual over-ride relates to the VLT Series 3000. The proposed control scheme is based on using 2 of the 4 menu set-ups. Menu set-up 1 has the parameters set for PI operation and Menu set-up 2 has the parameters set for manual control.

1. Set parameter 001 to multi set-up.
2. Set parameter 400 to select set-up.
3. Install an "Auto-Manual" switch across terminals 12 & 16. This will allow selection between the 2 menu set-ups. The bottom right hand corner of the display will show the menu set-up you are in.
4. Program menu set-up 1 for PI operation.
5. Select menu set-up 2 and alter the following parameters:
 - Parameter 100; Set to the same load type as in menu 1. You can check the parameter data in menu 2 against the parameter data in menu 1 by switching between menu set-ups while you are in that parameter.
 - Parameter 107-113; Set to the same load types as in menu 1.
 - Parameter 201-201; Max. and Min. Frequency can be set to suit manual control.
 - Parameter 209; Set to the same load type as in menu 1.
 - Parameter 215-216; Set the ramp times to suit the application.

- Parameter 315; Set the motor thermal overload protection to **trip 2**.
- Parameter 412; Set to **0-10 V**.
- Parameter 413; Set to **no operation**.

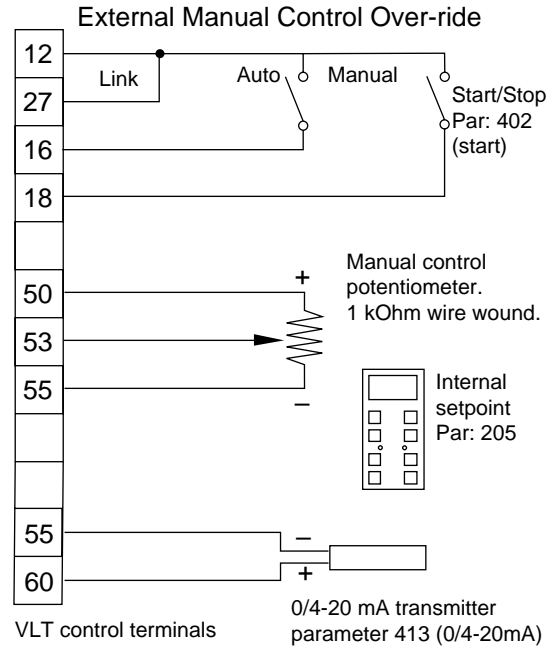

NOTE: All control wiring needs to be shielded and the shield grounded to the clamps as shown in the respective instruction manuals.

VLT SERIES 2000 PARAMETER GROUPS AND FACTORY DEFAULT SETTINGS

OPERATION and DISPLAY:	LOAD and MOTOR:	REFERENCES and LIMITS:	FUNCTIONS and TIMERS:	INPUTS and OUTPUTS:	SERIAL DATA INTERFACE:	SERVICE and DIAGNOSTICS:
000 LANGUAGE SELECT ^{S)} ENGLISH	101 SPEED CONTROL ^{2,S)} SLIP COMPENSATED	200 FREQUENCY RANGE 0-120 Hz	300 BRAKE FUNCTION ^{S)} NOT APPLIED	402 TERMINAL 18 START ^{S)} START	500 ADDRESS 1	606 TOTAL OPERATION HOURS
001 MENU SETUP SELECT ^{S)} SETUP 1	102 CURRENT LIMIT CONT. ^{S)} PROGRAMMED SET	201 MIN. FREQUENCY ^{2,S)} 0.00 Hz	306 DC BRAKING TIME ^{2,S)} 0	403 TERMINAL 19 REVERSING ^{S)} REVERSING	501 BAUD RATE 1.2 K	607 RUNNING HOURS
002 SETUP COPY DO NOT COPY	103 MOTOR POWER NOMINAL SIZE	202 MAX. FREQUENCY ^{2,S)} DEPENDING ON UNIT	307 DC BRAKE CUT-IN FREQUENCY ^{2,S)} 1	404 TERMINAL 27 STOP ^{S)} MOTOR COASTING	502* DATA READ-OUT ^{S)} OR	608 NUMBER OF POWER UPS
003 LOCAL REMOTE ^{S)} REMOTE	104 MOTOR VOLTAGE DEPENDING ON UNIT	203 JOG FREQUENCY ^{2,S)} 10	308 DC BRAKE VOLTAGE ^{2,S)} 10	405 TERMINAL 29 INPUT ^{S)} JOG	503* COASTING ^{S)} OR	609 NIMBER OVER-TEMP
004 LOCAL REFERENCE ^{S)} 0 Hz	105 MOTOR FREQUENCY DEPENDING ON UNIT	204 DIGITAL REF. TYPE ^{2,S)} SUM	309 RESET MODE ^{S)} MANUAL RESET	408 TERMINAL 46 OUTPUT ^{S)} UNIT READY	504* Q-STOP ^{S)} OR	610 NUMBER OF OVER-VOLTAGE
005 DISPLAY VALUE ^{S)} 1000	107 MOTOR CURRENT ^{2,S)} DEPENDING ON UNIT	205 DIGITAL REF. 1 ^{2,S)} 00.0	310 TRIP DELAY AT CURRENT LIMIT ^{S)} INFINITE	409 TERMINAL 01 RELAY OUTPUT ^{S)} READY	505* DC BRAKE ^{S)} OR	
006 LOCAL RESET ^{S)} ENABLE	108 MOTOR MAGNETIZE ^{2,S)} DEPENDING ON UNIT	206 DIGITAL REF. 2 ^{2,S)} 0	315 MOTOR THERMAL ^{2,S)} PROTECTION OFF	411 ANALOG REF. TYPE ^{S)} LINEAR	506* START ^{S)} OR	
007 LOCAL START/STOP ^{S)} ENABLE	109 START VOLTAGE ^{2,S)} DEPENDING ON UNIT	207 DIGITAL REF. 3 ^{2,S)} 0		412 TERMINAL 53 ANALOG VOLTAGE ^{2,S)} 0-10VDC	507* DIRECTION ^{S)} DIGITAL	
008 LOCAL REVERSING ^{S)} DISABLE	110 START COMP ^{2,S)} DEPENDING ON UNIT	208 DIGITAL REF. 4 ^{2,S)} 0		413 TERMINAL 60 ANALOG I ^{2,S)} 0-20 mA	508* RESET ^{S)} OR	
009 LOCAL JOGGING ^{S)} ENABLE	111 U/F RATIO ^{2,S)} DEPENDING ON UNIT	209 CURRENT LIMIT ^{2,S)} DEPENDING ON UNIT			509* SET-UP SELECT ^{S)} OR	
010 LOCAL SPEED SELECT ^{S)} ENABLE	112 SLIP COMP ^{2,S)} DEPENDING ON UNIT	210 WARN FREQ. LOW ^{2,S)} 0			510* SPEED SELECT ^{S)} OR	
013 DATA CHANGE LOCK ^{S)} NOT LOCKED	114 FEEDBACK SIGNAL ^{S)} CURRENT 20mA	211 WARN FREQ. HIGH ^{2,S)} f_{RANGE} (from 200)			511 BUS JOG 1 ^{S)} 10	
	119 FEED FWD FACTOR ^{2,S)} 100%	213 WARN CURRNT HIGH ^{2,S)} $I_{VLT MAX}$ (from 209)			514 BUS BIT 4 ^{S)} Q-STOP	
	120 CONTROL RANGE ^{42,S)} 100%	215 RAMP-UP TIME ^{2,S)} 5 SEC			516 BUS REFERENCE ^{S)} 0	
	121 PROPORTION GAIN ^{2,S)} 0.01	216 RAMP-DOWN TIME ^{2,S)} 5 SEC			517 STORE DATA VALUES ^{S)} OFF	
	122 INTEGRAL TIME ^{2,S)} OFF	218 QUICK-STOP RAMP 1 SEC				
	125 FEEDBACK SCALING ^{2,S)} 100%	224 CARRIER FREQ ^{2,S)} 4.5				
		230 SPEED UP/DOWN DISABLE				

DISPLAY MODE

READOUTS:

REFERENCE %
 FREQUENCY Hz
 DISPLAY FEEDBACK "UNIT"
 CURRENT A
 TORQUE %
 POWER kW
 POWER HP
 ENERGY kWh
 OUTPUT VOLTAGE V
 DC VOLTAGE V
 MOTOR ETR value %
 INVERTER ETR value %

2) AVAILABLE IN BOTH SETUPS
 S) CAN BE CHANGED IN START MODE (RUNNING MOTOR)

* NOTE: Menu 502 can only be selected from the bus. These values are read-only values.

The PC/PLC may prompt for a value from an index between 0 and 19.

In parameters 503 to 510 you can choose to control the VLT adjustable frequency drive via the control unit's terminals (digitally) and or via the bus.

When using *Logical* and *Bus* values in parameters 503-510, the digital control terminals are either dependent on or overruled by the bus commands.

OPERATION & DISPLAY:	LOAD & MOTOR:	REFERENCES & LIMITS:	FUNCTIONS & TIMERS:	INPUTS & OUTPUTS:	SERIAL DATA INTER.:	SERVICE & DIAG.:
000	101	200	300	402	500	606
001	102	201	306	403	501	607
002	103	202	307	404	502*	608
003	104	203	308	405	503*	609
004	105	204	309	408	504*	610
005	107	205	310	409	505*	
006	108	206	315	411	506*	
007	109	207		412	507*	
008	110	208		413	508*	
009	111	209			509*	
010	112	210			510*	
013	114	211			511	
	119	213			514	
	120	215			516	
	121	216			517	
	122	218				
	125	224				
		230				

* NOTE: Menu 502 can only be selected from the bus. These values are read-only values. The PC/PLC may prompt for a value from an index between 0 and 19. In parameters 503 to 510 you can choose to control the VLT adjustable frequency drive via the control unit's terminals (digitally) and or via the bus. When using *Logical* and *Bus* values in parameters 503-510, the digital control terminals are either dependent on or overruled by the bus commands.

CUSTOMER PARAMETER SETTINGS