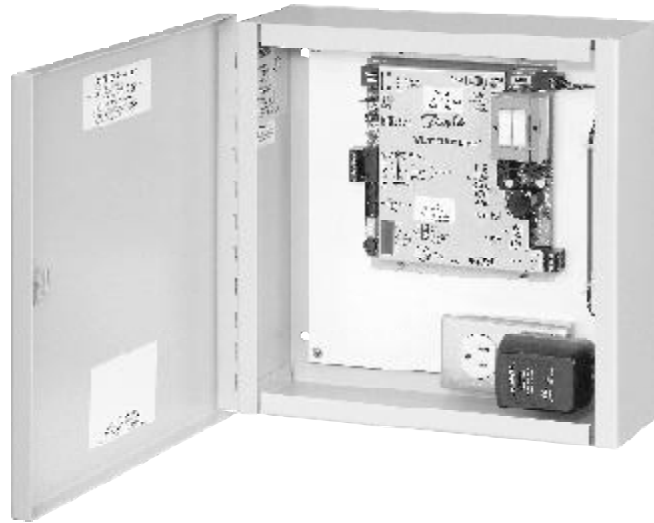




---

# VLT<sup>®</sup> 6000 and VLT<sup>®</sup> 2800

## Adjustable Frequency Drives



## BACLink<sup>®</sup>

# Instruction Manual



## Table of Contents

Introduction .....	5
About this manual .....	5
References .....	5
Trademarks .....	5
Mounting requirements .....	7
Wiring and terminal tightening specifications .....	7
Electrical wiring .....	8
VLT 6000 network connection .....	9
VLT 6000 termination switch settings .....	9
VLT 6000 network wiring .....	9
VLT 6000 BACnet start up .....	10
Changing VLT 6000 parameter data .....	10
VLT 2800 network connection .....	11
VLT 2800 BACnet start up .....	11
Changing VLT 2800 parameter data .....	11
Ethernet network connection .....	12
Wiring .....	12
Set IP address of portal .....	13
Set configuration jumpers on portal .....	13
ARCnet network connection .....	14
EIA-485 network connection .....	15
EIA-232 network connection .....	16
Power up .....	17
Troubleshooting drive communication .....	17
Troubleshooting Ethernet communication .....	17
Loss of signal recovery time .....	17
Appendix: BACnet POINT MAPPING TABLES for BACLink PORTAL .....	18

## Introduction

The Danfoss BACLink<sup>®</sup> is a microprocessor based communication portal that provides seamless translation between BACnet and Danfoss VLTs. The portal supports BACnet communications through Ethernet, BACnet IP over Ethernet (often referred to as Ethernet IP), ARCnet, EIA-485 (using MS/TP), or EIA-232 (PTP). The BACLink portal provides a dedicated Ethernet port and two serial communication ports which can be configured for different protocols. Baud rates are software selectable. An optional EIA-485 4-wire connection is also available to extend network cable length beyond 4000 feet.

Do not input multiple protocol formats to the portal at the same time since this can cause a communications loop and generate excessive electrical noise.

BACLink accesses the Johnson Controls Metasys<sup>®</sup> N2 protocol resident in the Danfoss VLT<sup>®</sup> 2800 and VLT<sup>®</sup> 6000 Adjustable Frequency Drives. The BACLink port operates with an internal ARCnet operating protocol. Recommended connection is through EIA-485 compatible, half duplex, 9600 baud, shielded twisted-pair wiring. Data points in the N2 database are classified as analog I/O (floating point), binary I/O or integer data points. Each data type has a unique structure defined in the Metasys N2 system *Protocol Specification for Vendors*.

An appendix at the back of this manual contains the drive point maps for BACnet.

## About this manual

The information in this manual is intended to provide comprehensive information on installation and set up of the VLT for communication over a BACnet network.

It is assumed that the user has knowledge of the capabilities of the BACnet network in addition to an understanding of the Danfoss VLT 2800 and VLT 6000 drives. For specific information on operation of the drive, refer to the *Installation, Operation and Maintenance Manual for the VLT 6000* or the *Operating Instructions for the VLT 2800*.

## References

In addition to this manual, the following manuals may be referenced:

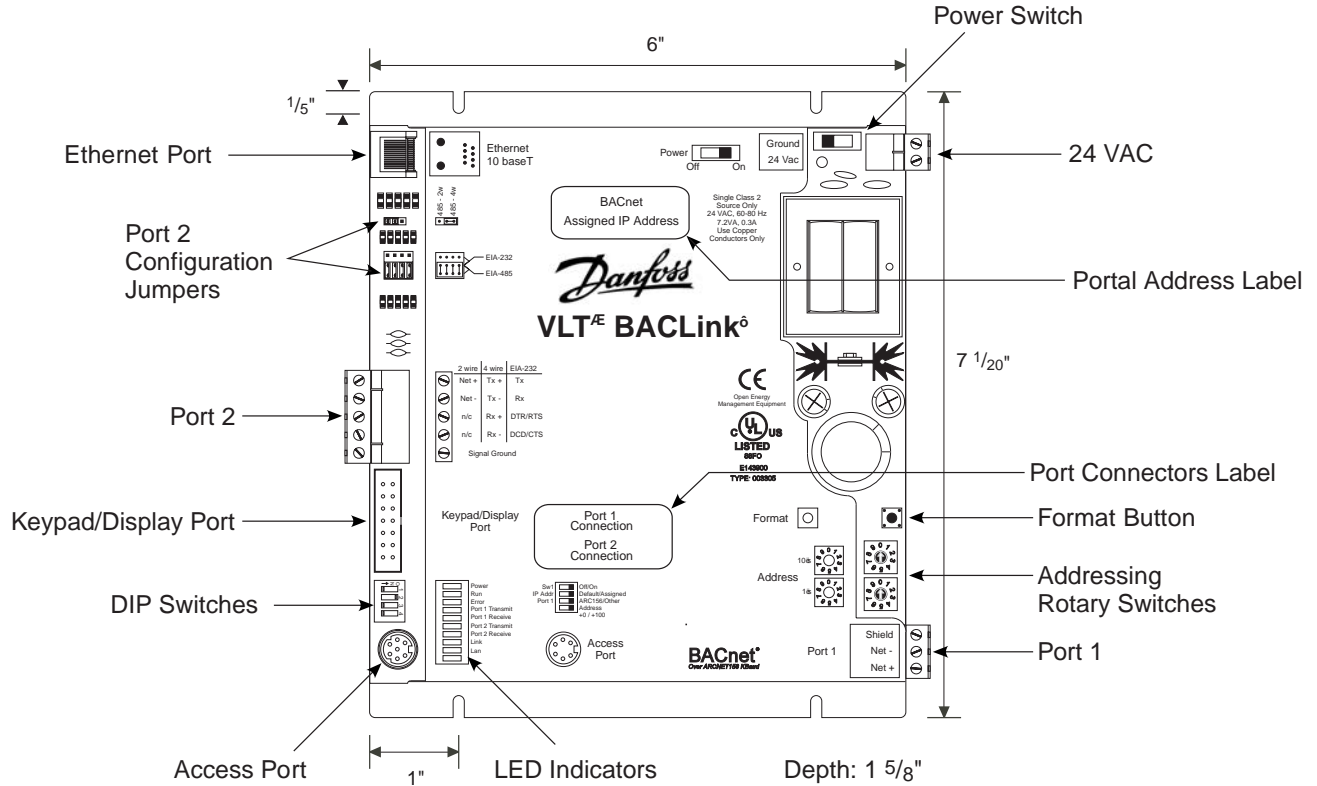
*Installation, Operation and Maintenance Manual for the VLT<sup>®</sup> 6000 Adjustable Frequency Drive*, Danfoss Graham number 23-6108-00.

*Operating Instructions for the VLT<sup>®</sup> 2800*, Danfoss number MG28Axxx

*Johnson Controls Metasys<sup>®</sup> N2 System Protocol Specification for Vendors*, Johnson Controls number 04-3402-22.

## Trademarks

Metasys<sup>®</sup> N2 is a Johnson Controls Inc registered trademark. VLT<sup>®</sup> is a Danfoss registered trademark.



**Figure 1. BACLink Portal**

**Power switch.** Two position on/off power switch.

**Portal address label.** Identifies factory-set or default portal addresses.

**Port connectors label.** Identifies factory-settings for communication ports 1 and 2. Default setting for port 1 is unassigned. Default setting for port 2 is EIA-485.

**24 VAC connector.** Input power for BACLink module.

**Format button.** Normally not used with BACnet. Contact the Danfoss Graham service department for information on its use to clear factory-set programming.

**Address rotary switches.** Rotary switches used to set BACLink portal network addresses. Set addresses 01-99 with DIP switch 5 in the +0 position. Set addresses 100-199 with DIP switch 5 in the +100 position.

**Port 1.** Preferred port for ARCnet connection. Selectable for ARCnet or 2-wire EIA-485. Set DIP switch 4 (Port 1) to *Other* to enable linking drives with EIA-485 wiring. Set DIP switch 4 (Port 1) to *ARC156* for use as ARCnet connector. (See DIP switches.)

**LED indicators.** Status indicator lights for functions as labeled.

**Access port.** Utility port for factory programming, set up, and to assign the IP address. The access port cannot be used as a communication point or to download memory to the BACLink.

**DIP switches.** Two position switches used to enable selection of IP address, module address, and network type. Sw1 and Sw2 are disabled in VLT communication applications.

**Keypad/Display port.** Access port for optional keypad.

**Port 2.** Preferred port for EIA-485 connection to the VLT drives. The terminal is jumper selectable for 2-wire/4-wire EIA-485 or EIA-232. Default setting is EIA-485 (2-wire).

**Port 2 configuration jumpers.** Jumper placement determines the configuration for EIA-485 (2-wire), EIA-485 (4-wire), or EIA-232 communication for Port 2. Default is EIA-485 2-wire.

**Ethernet port.** Ethernet network connector supports 10baseT network communication with BACLink.

## Mounting requirements

Mount the BACLink enclosure as required using the predrilled mounting holes (see Figure 2). The unit weighs approximately 15.3 pounds (7 kg).

For BACLink portals ordered without an enclosure, mount the unit in an enclosed panel using the mounting holes provided on the BACLink portal backplate (refer back to Figure 1). Leave about 2 inches (5 centimeters) on each side for wiring access. In addition, the BACLink portal requires 24 VAC input power.

## **⚠ WARNING**

**BACLink portal is a Class 2 device (less than 30VAC, 100VA maximum). Take appropriate isolation measures when mounting BACLink portal in control panels where non-Class 2 devices (for example, 120VAC) or wiring are present.**

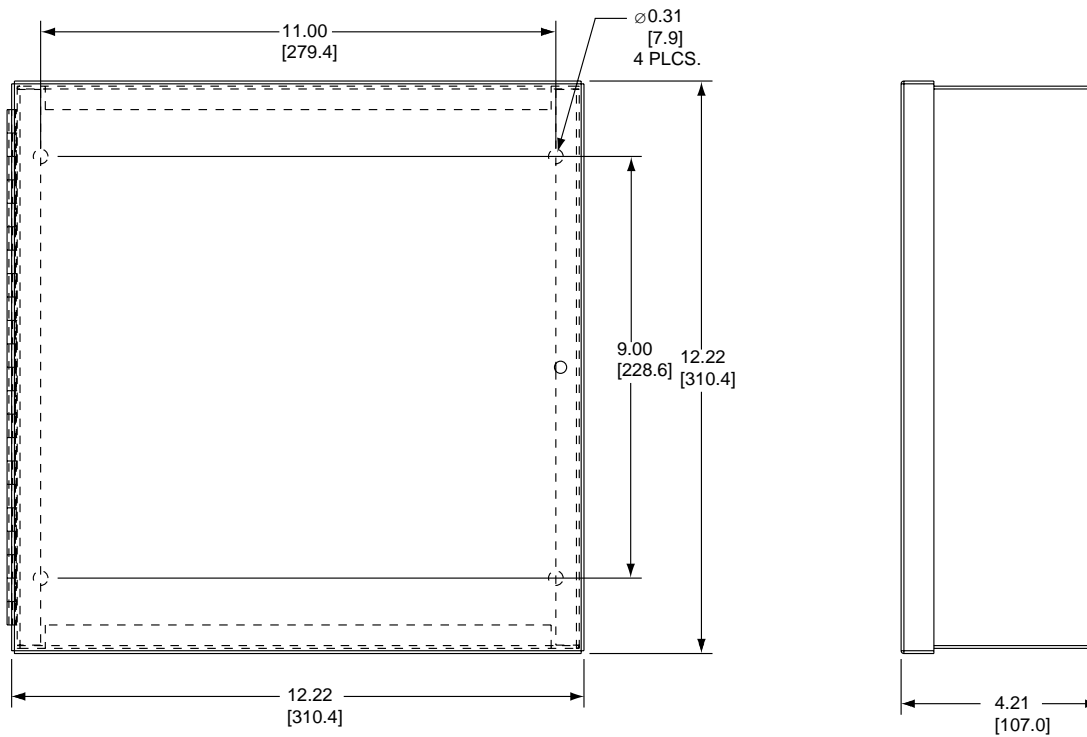
## Wiring and terminal tightening specifications

Terminal tightening and wire specifications for the VLT 2800 and VLT 6000 are defined in Table I.

Total wiring length to connect up to 10 VLT 6000 and VLT 2800 drives from the BACLink portal should not exceed 3,000 feet (900m) at 9600 baud rate.

**Table I. Control Wiring and Torque Specifications**

Torque Specification	Control Wiring	24 VAC Input Wiring
4.5 in-lbs (0.5 Nm)	18 – 24 AWG (0.75mm <sup>2</sup> – 0.2mm <sup>2</sup> ) shielded twisted pair	22 AWG (0.3mm <sup>2</sup> )

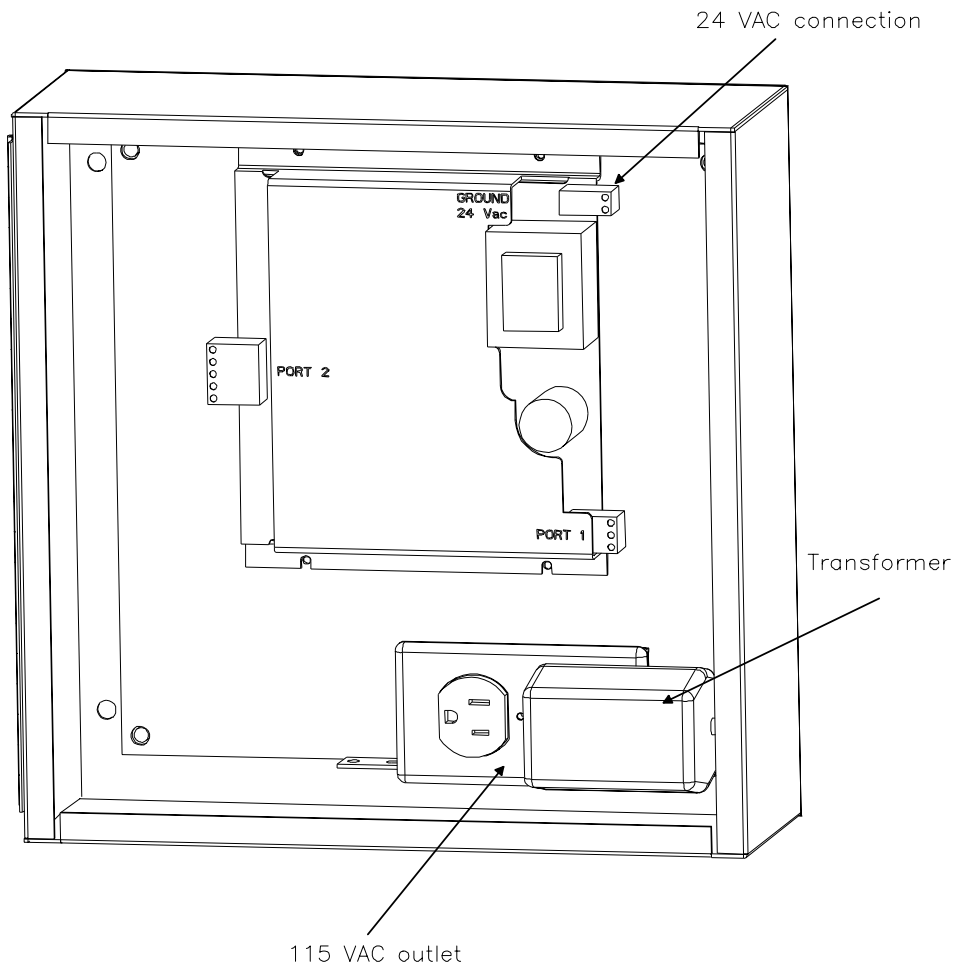


NOTE: Dimensions in inches [mm].

**Figure 2. BACLink Enclosure Mounting Dimensions**

### Electrical wiring

1. Power must be supplied to the 115 VAC outlet from an external source (see Figure 3).
2. Plug transformer into 115 VAC outlet.
3. Connect transformer cable to 24 VAC connector on BACLink board.



**Figure 3. BACLink Enclosure Electrical Components**

## VLT 6000 network connection

### VLT 6000 termination switch settings

DIP switches 2 and 3 on the main control board of the VLT 6000 (see Figure 4) are used to configure the drive for BACnet serial bus termination. The switch position shown is the factory setting. See Table II for setting information. The DIP switch are located directly above terminals 61, 68 and 69 on the board.

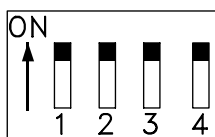


Figure 4. VLT 6000 DIP Switch

### VLT 6000 network wiring

1. Connect signal wires to drive terminal 68 (P+) and terminal 69 (N-) on main control board of drive (see figure 5).
2. If shielded cabling is used, connect one end of shield to terminal 61. This terminal is connected to ground via an internal RC link.

For additional wiring guidelines, see the procedures for specific network-type connections in this manual.

#### NOTE

**It is highly recommended to use shielded, twisted-pair wires to reduce electrical noise on drive communications. Ensure that drive is grounded properly according to instructions in the drive manual.**

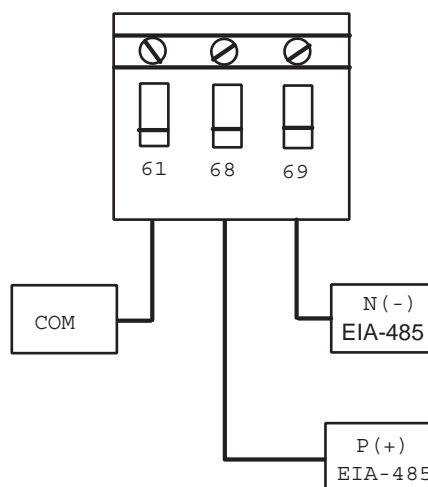


Figure 5. VLT 6000 Network Wiring

Table II. VLT 6000 DIP Switch Settings

SWITCH	SETTING
Switch 1	Reserved/No function
Switches 2 & 3	Used for terminating an EIA-485 interface. When the drive is the first, last, or only device on a network, switches 2 and 3 must be ON.  When the drive is in any other location on the network, switches 2 and 3 must be OFF.
Switch 4	Not applicable with BACnet.



## VLT 6000 BACnet start up

The BACLlink portal will have factory default settings ready for operation without user adjustment. **Parameters 500, 501 and 502 must be set as shown in Table III.** Other settings may be changed to meet application requirements. Refer to the *VLT 6000 Installation, Operation and Maintenance Manual* for details on programming the drive.

The appendix in this manual lists point maps for BACnet.

## Changing VLT 6000 parameter data

Use the VLT 6000 keypad to access the Extended Menu key and the 500 Group (serial communication) parameters. Enter or change parameter data or settings in accordance with the following procedure.

1. Press [Extend Menu] key.
2. Use ◀ and ▶ keys to find parameter group to edit.
3. Use [+] and [-] keys to find parameter you chose to edit.
4. Press [Change Data] key.
5. Use [+] and [-] keys to select correct parameter setting.
6. Press [Cancel] key to disregard change, or press [OK] key to accept change and enter new setting.
7. Press [Display Mode] key to return to normal drive display.

**Table III. VLT 6000 Serial Communication Startup Parameter Settings**

Parameter	Name	Setting
500	Protocol	METASYS N2
501	Address	<b>01</b>
502	Baud rate	<b>9600 BAUD (fixed at 9600 for N2 protocol)</b>
503	Coasting	<b>LOGIC OR</b>
504	DC brake	<b>LOGIC OR</b>
505	Start	<b>LOGIC OR</b>
506	Reversing	<b>DIGITAL INPUT</b>
507	Select setup	<b>LOGIC OR</b>
508	Select speed	<b>LOGIC OR</b>
560	Override release time	<b>OFF</b>

The values in **bold** are default values.

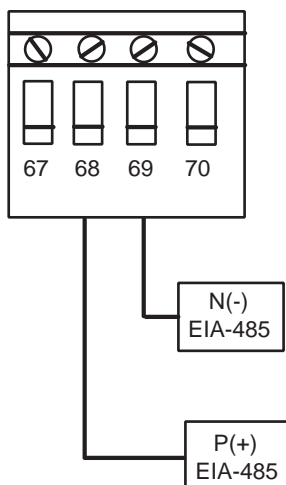
## VLT 2800 network connection

1. Connect signal wires to drive terminal 68 (P+) and terminal 69 (N-) on main control board of drive (see Figure 6).
2. If shielded cabling is used, observe standard shielding practice by grounding shielded wiring at only one point in system.

For additional wiring guidelines, see the procedures for specific network-type connections in this manual.

### NOTE

**It is highly recommended to use shielded, twisted-pair wires to reduce electrical noise on drive communications. Ensure that drive is grounded properly according to instructions in the drive manual.**



**Figure 6. VLT 2800 Network Connection**

## VLT 2800 BACnet start up

The BACLink portal will have factory default settings ready for operation without user adjustment.

**Parameters 500, 501 and 561 must be set as shown in Table IV.** Other settings may be changed to meet application requirements. The settings shown will serve as a good starting reference. Refer to the *VLT 2800 Operating Instructions* for details on changing parameters and programming the drive.

The appendix in this manual lists point maps for BACnet.

### Changing VLT 2800 parameter data

Use the VLT 2800 keypad to access the Menu Mode and the 500 Group (serial communication) parameters. Enter or change parameter data or settings in accordance with the following procedure.

1. Press [Quick Menu] and [+] key at same time to enter menu mode.
2. Use [+] and [-] keys to find parameter you chose to edit.
3. Press [Change Data] key.
4. Use [+] and [-] keys to select correct parameter setting.
5. Press [Change Data] key to accept change and enter new setting or press [Quick Menu] key to disregard change.
6. Press [Quick Menu] key to return to display mode.

**Table IV. VLT 2800 Serial Communication Startup Parameter Settings**

Parameter	Name	Setting
500	Address	<b>001</b>
501	Baud rate	<b>9600 BAUD</b> (fixed at 9600 for N2 protocol)
502	Coasting	<b>LOGIC OR</b>
503	Quick stop	<b>LOGIC OR</b>
504	DC brake	<b>LOGIC OR</b>
505	Start	<b>LOGIC OR</b>
506	Reversing	<b>LOGIC OR</b>
507	Select setup	<b>LOGIC OR</b>
508	Select speed	<b>LOGIC OR</b>
560	N2 Override release time	<b>OFF</b>
561	Protocol	<b>METASYS N2</b>

The values in bold are default values.

## Ethernet network connection

The Ethernet network connects directly to the BACLink Ethernet portal (refer back to Figure 1). The connection is a 10baseT port. Both Ethernet and Ethernet IP (BACnet IP) connect through this connector.

To establish Ethernet communication with the BACLink portal and VLT drives, the following must be completed:

1. Wiring
2. Setting IP address of portal
3. For port 2 connection, setting port 2 configuration jumpers

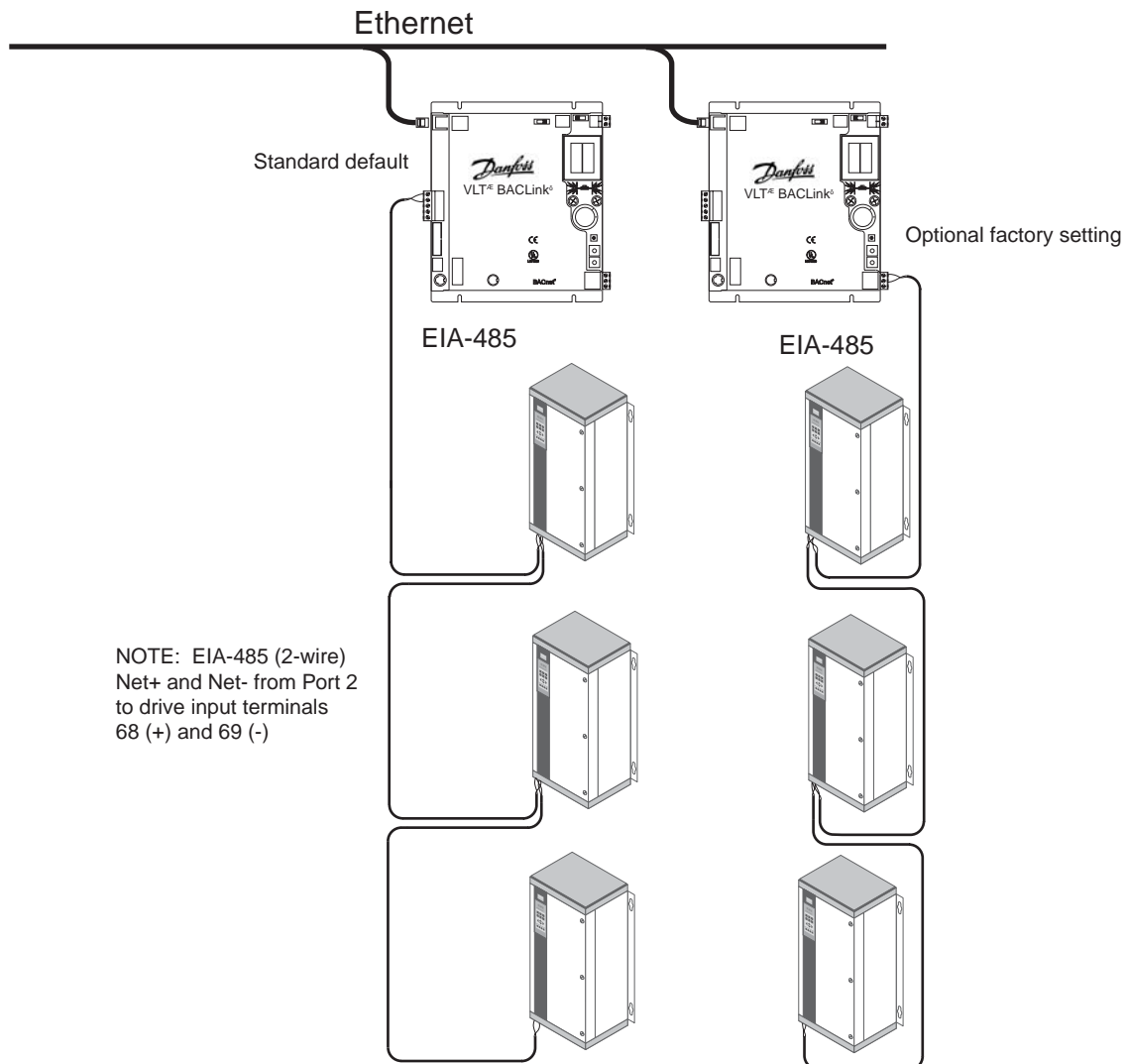
## Procedure

### 1. Wiring

**Wire Connections.** Each BACLink portal can support up to 10 drives (see Figure 7). Any mix of VLT 2800 or VLT 6000 drives is supported.

The preferred portal-to-drive wiring is EIA-485 from port 2. Connect portal Net+ to drive terminal 68 (+) and Net- to 69 (-). Additional drives are connected pos-to-pos and neg-to-neg in daisy chain fashion.

If required, port 1 can be factory-configured to connect the drives through EIA-485.



**Figure 7. Ethernet Network Connection**

**NOTE**

**Steps 2 and 3 in the following connection procedure may have already been factory-set based upon customer ordering information. Default IP address is 192.168.168.xxx. Default subnet mask is 255.255.255.0. Default gateway address is 0.0.0.0.**

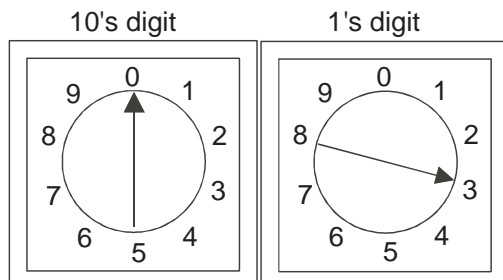
**2. Set IP address of portal**

**A. Set IP address to default or assigned.** The BACLink portal has either an internal default Internet Protocol (IP) address or a factory-set IP address assigned from customer input. See the label attached to the portal for the IP address in either case (refer back to Figure 1). An IP address must always be present for Ethernet IP network communication. Set the IP address DIP switch (switch 3 in Figure 8) on the BACLink portal as either default or assigned. (Switches 1 and 2 are disabled.)



**Figure 8. BACLink DIP Switches**

**B. Set BACLink default address.** The default IP address is 192.168.168.xxx. The xxx indicates the final portion of the IP address which is set using the rotary switches on the BACLink portal. The final portion of the address identifies the BACLink portal with a unique address on the BACnet network. For example, using the default address, Figure 9 shows the BACLink portal address configured as 192.168.168.3. Set the user-assigned final portion of the portal network address using the rotary switches.



**Figure 9. Rotary Address Switches**

For Ethernet connection without IP, an IP address is not used. Use the rotary address switches to assign the media access control (MAC) address.

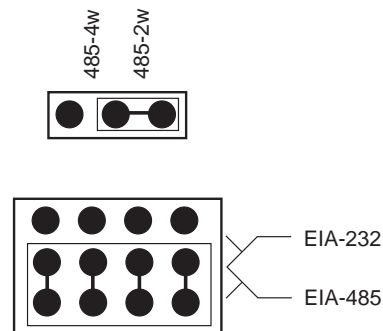
**C. Set BACLink portal address DIP switch.** The BACLink portal DIP switch 5 (refer back to Figure 8) must correspond to the final portion of the IP address setting. Set the switch to +0 for addresses 0 to 99 or to +100 for addresses 100 to 199.

**3. Set configuration jumpers on portal**

See the port connector label attached to the BACLink portal for the factory-configured port assignments (refer back to Figure 1).

**Set port 2 configuration jumpers for communication type.**

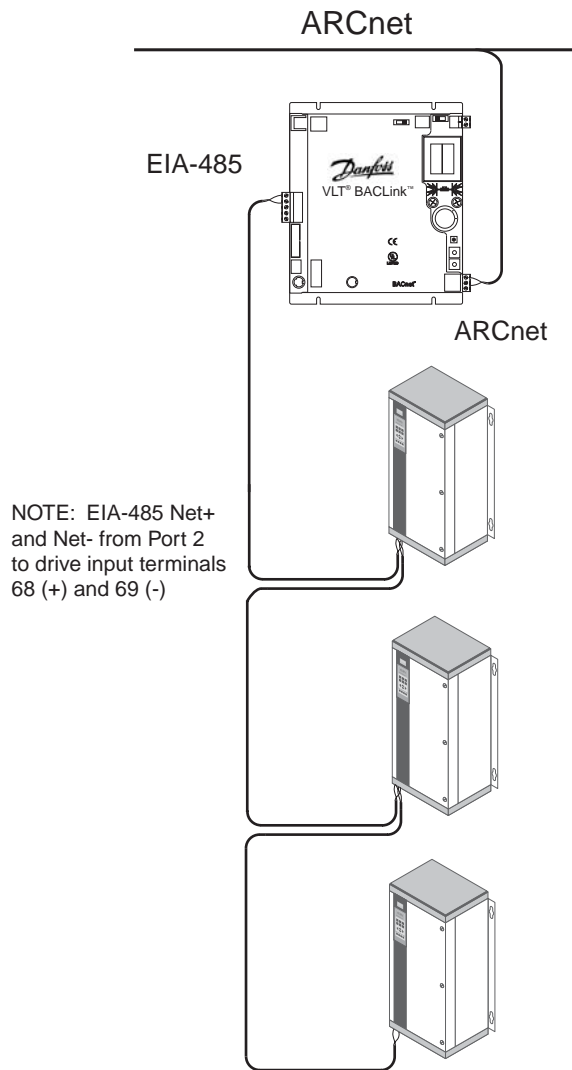
When using port 2 on the BACLink portal for communication with the drives, set the port 2 configuration jumpers for EIA-485 (2-wire). Figure 10 illustrates the appropriate setting. EIA-485 (2-wire) is the factory default setting.



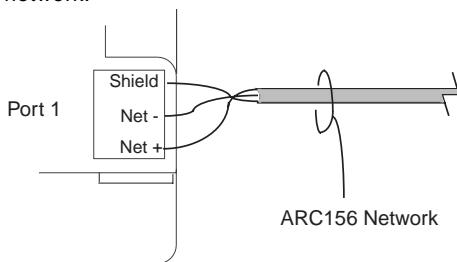
**Figure 10. Port 2 Configuration Jumpers**

**When using port 1.** Port 1 must be programmed for operation at the factory based upon customer ordering data. When using port 1 on the BACLink portal for communication with the drives, set the port 1 DIP switch (refer back to Figure 8) for *ARC156* when using an ARCnet interface to the drives or *Other* for EIA-485 or additional options.

## ARCnet network connection



NOTE: Terminate shield at only one portal of a multiportal network.



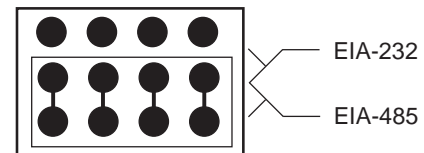
**Figure 11. ARCnet Network Connection**

## Procedure

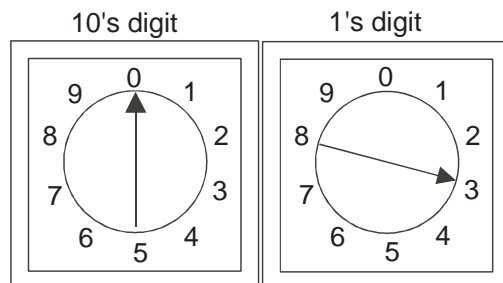
1. Switch BACLink portal power off.
2. Wire ARCnet network input cable to BACLink port 1 (see Figure 11).
3. Set port 1 DIP switch to ARC156 (see Figure 12).
4. Plug EIA-485/232 configuration jumper to EIA-485 position as shown in Figure 13.
5. Set portal device instance number using rotary address switches (see Figure 14).
6. Set BACLink portal address DIP switch. BACLink portal DIP switch 5 (refer back to Figure 1) must correspond to device instance number setting. Set switch to +0 for addresses 0 to 99 or to +100 for addresses 100 to 199.
7. Wire to drives from BACLink port 2 from Net (+) to drive terminal 68 and Net (-) to drive terminal 69.



**Figure 12. BACLink DIP Switches**

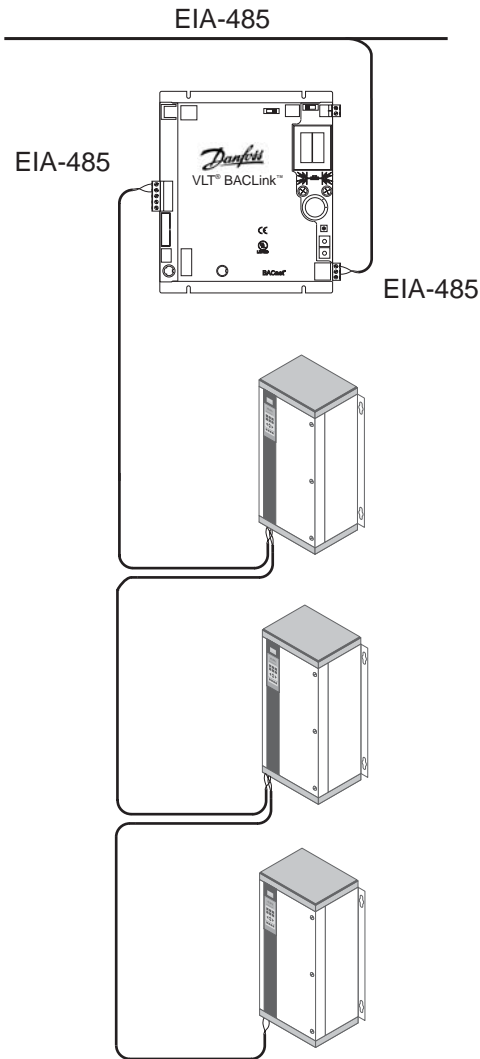


**Figure 13. Port 2 Configuration Jumper Settings**



**Figure 14. Rotary Address Switches**

## EIA-485 network connection



NOTE: EIA-485 (2-wire)  
from Port 2 to drive input  
terminals 68 (+) and 69 (-)

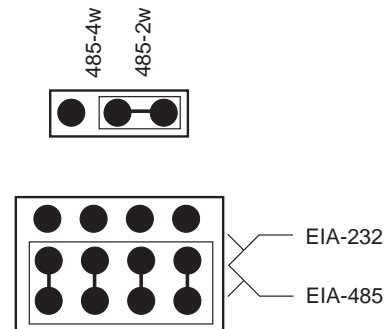
**Figure 15. EIA-485 (2-wire) Network Connection**

## Procedure

1. Switch BACLink portal power off.
2. Wire EIA-485 network input cable to BACLink port 1 (see Figure 15).
3. Set port 1 DIP switch to *Other* (see Figure 16).
4. Plug EIA-485/232 configuration jumper to EIA-485 position as shown in Figure 17.
5. Plug EIA-485 configuration jumper to (2-wire) position as shown in Figure 17.
7. Wire to drives from BACLink port 2 from Net (+) to drive terminal 68 and Net (-) to drive terminal 69.

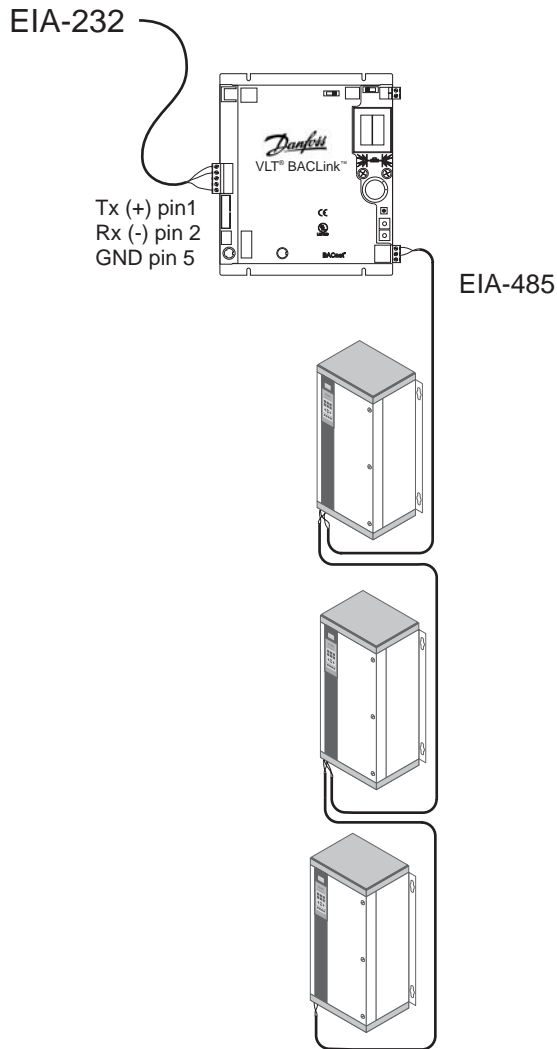


**Figure 16. BACLink DIP Switches**



**Figure 17. Port 2 Configuration Jumper Settings**

### EIA-232 network connection



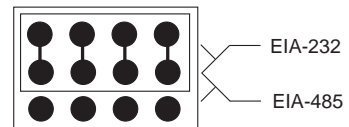
**Figure 18. EIA-232 Network Connection**

### Procedure

1. Switch BACLink portal power off.
2. Wire EIA-232 network input cable to BACLink port 2 (see Figure 18). Tx (+) pin 1, Rx (-) pin 2, GND pin 5.
3. Set port 1 DIP switch to *Other* (see Figure 19).
4. Plug EIA-485/232 configuration jumper to EIA-232 position as shown in Figure 20.
5. Wire to drives from BACLink port 2 from Net (+) to drive terminal 68 and Net (-) to drive terminal 69.



**Figure 19. BACLink DIP Switches**



**Figure 20. Configuration Jumper Settings**

## Power up

1. Turn BACLink power switch to OFF. This prevents BACLink from power up before proper voltage is verified.
2. Ensure that power is applied to the drives.
3. Plug connector from transformer to BACLink 24 VAC power terminal.
4. Ensure that 24 VAC is present at BACLink power input terminals.
5. Turn BACLink power switch to ON. Power, Run and Error LEDs turn on. Run and Error LEDs then begin blinking. Error LED turns off.

## Troubleshooting drive communication

For use in the event of trouble communicating with the drives. Test conditions for BACLink portal communications:

1. Test only one drive connected to portal at a time.
2. Portal power OFF.

3. For VLT 6000, termination DIP switches 2 and 3 should be in the ON position. Termination DIP switches are located on VLT 6000 power board directly above drive terminals where connections to terminals 68 and 69 are made.
4. Drive power ON.
5. Apply power to portal and wait 20-25 seconds. (See Table V for test results.)

## Troubleshooting Ethernet communication

With the BACLink portal connected to BACnet network through the Ethernet connector, apply power to BACLink portal and switch portal ON. See Table VI for test results.

## Loss of signal recovery time

When serial communication is lost to the drive, recovery time to reestablish communication with the network can take up to 5 minutes.

**Table V. Troubleshooting Drive Communication**

SYMPTOM	CAUSE	SOLUTION
Transmit LED ON steady and receive LED OFF.	Reversed polarity to drive or short in EIA-485 cable.	Reverse wires to drive terminals 68 (+) and 69 (-) or remove short.
Transmit LED blinks slowly 3 times, then pauses and repeats 3 blinks.	<ul style="list-style-type: none"> <li>• Drive not ON.</li> <li>• Drive not set for N2 protocol in parameter 500.</li> <li>• Drive serial bus address not correct in parameter 501.</li> <li>• Network cable not connected.</li> <li>• For VLT 6000: termination switches on drive in wrong position.</li> </ul>	<ul style="list-style-type: none"> <li>• Apply power to drive.</li> <li>• Set parameter 500 for N2 protocol.</li> <li>• Set drive address in parameter 501.</li> <li>• Connect network cable to unit.</li> <li>• Set termination switches 2 and 3 to ON position.</li> </ul>

**Table VI. Troubleshooting Ethernet Communication**

SYMPTOM	CAUSE	SOLUTION
Link LED is OFF. Lan LED is OFF.	<ul style="list-style-type: none"> <li>• Network speed set to 100kbps.</li> <li>• BACLink board not connected to network</li> <li>• Portal address not set for network or not recognized.</li> </ul>	<ul style="list-style-type: none"> <li>• Set network speed for 10kbps.</li> <li>• Connect board to network.</li> <li>• Ping portal to test communications. To ping portal, go to a DOS prompt on any network computer. Type "ping" and the portal address (displayed on the IP address label on the unit) and press enter. If communicating, you will get a reply. If not communicating, you will get no response indication.</li> </ul>



## Appendix

### BACnet POINT MAPPING TABLES for BACLink PORTAL

#### Binary Inputs to Drive

BACnet REFERENCE NUMBER	DESCRIPTION	RANGE
coast_#	Motor will coast freely to a stop. Drive will not run in any mode when coast is active.	<b>0=Coast stop</b> 1=No coast
start_#	Provides a start command when active. Motor will ramp to stop when stop is active.	<b>0=Stop</b> 1=Start
reset_#	Allows resetting drive after a fault that does not require cycling power. Reset occurs at transition from OFF to ON.	<b>0=Off</b> 1=On
jog_#	Used to start and run drive at a frequency set in parameter 209.	<b>0=Off</b> 1=On
vlt2800_relay_#	Enables/disables high voltage Form C relay when parameter 323 is set to <i>Control Word Bit 11</i> [26] (for VLT 2800 only).	<b>0=Off</b> 1=On
vlt6000_relay_2_#	Enables/disables low voltage Form A relay when parameter 323 is set to <i>Control Word Bit 11/12</i> [29] (for VLT 6000 only).	<b>0=Off</b> 1=On
vlt6000_reverse_#	Changes motor direction of rotation when parameter 506 is set to a value other than <i>Digital Input</i> (for VLT 6000 only).	<b>0=Off</b> 1=On
relay_1_and_reverse_#	For VLT 2800, changes motor direction of rotation. For VLT 6000, enables/disables high voltage Form C relay when parameter 323 is set to <i>Control Word Bit 11/12</i> [29].	<b>0=Off</b> 1=On

The values in bold are default values.

#### NOTE

**Binary input point 9 commands two different functions. For VLT 2800, it commands reverse function to change direction of motor rotation. For VLT 6000, it can command the state of Form C relay.**

## Analog Inputs to Drive

BACnet REFERENCE NAME	DESCRIPTION	RANGE	VLT 6000 PARA No.	VLT 2800 PARA No.
bus_ref_#	Drive speed command (open loop) or setpoint (closed loop) via the serial bus.	0% to 100%	N/A	N/A
bus_feedback_#	Drive feedback value via the serial bus.	0% to 100%	535	535
bus_feedback_2_#	Second drive feedback value via the serial bus available in the VLT 6000 only.	0% to 100%	536	VLT 6000 only

**NOTE:** # symbol represents drive ID number.

*Bus reference.* When the drive is set for open loop operation in parameter 100, the bus reference is the speed command to the drive. In closed loop operation, bus reference is the drive's setpoint.

*Bus feedback.* This is the feedback signal provided to the drive via the BACnet bus. The VLT 6000 can regulate two feedback signals provided to the drive.

*Range.* Percentage of range between minimum reference (parameter 204) and maximum reference (parameter 205).

## Drive Settings

BACnet REFERENCE NAME	DESCRIPTION	RANGE	VLT 6000 PARA NO.	VLT 2800 PARA NO.
vlt6000_reset_counter_#	Resets kWh counter (for VLT 6000 only)	<b>0=no rest</b> 1=reset	618	VLT 6000 only
vlt6000_active_setup_#	Selects active setup (for VLT 6000 only)	1 to 4	002	VLT 6000 only
vlt2800_prop_gain_#	PID proportional gain (for VLT 2800 only)	0.00 to 10.00	VLT 2800 only	440
vlt2800_int_time_#	PID integration time (for VLT 2800 only)	0.01 to 9999.00 sec.	VLT 2800 only	441
vlt2800_fb_filter_time_#	Feedback filter time (for VLT 2800 only)	0.01 to 10.00 sec.	VLT 2800 only	444
warn_feedback_low_#	Warning low feedback (for VLT 6000 only)	-999,999.999 to FB high	227	VLT 6000 only
warn_feedback_high_#	Warning high feedback (for VLT 6000 only)	FB low to 999,999.999	228	VLT 6000 only
setpoint_1_#	Set point 1 (for VLT 6000 only)	Min. FB to max. FB	418	VLT 6000 only
setpoint_2_#	Set point 2 (for VLT 6000 only)	Min. FB to max. FB	419	VLT 6000 only
vlt6000_prop_gain_#	PID proportional gain (for VLT 6000 only)	0.00 to 10.00	423	VLT 6000 only
vlt6000_int_time_#	PID integration time (for VLT 6000 only)	0.01 to 9999.00 sec.	424	VLT 6000 only
vlt6000_fb_filter_time_#	Feedback filter time (for VLT 6000 only)	0.01 to 10.00 sec.	427	VLT 6000 only

**NOTE:** # symbol represents drive ID number.

The values in bold are default values.



## Analog Outputs from Drive

BACNet Reference Name	UNIT	DESCRIPTION	VLT 6000 PARA NO.	VLT 2800 PARA NO.
reference_#	%	Reference in % between min and max reference. Speed reference in open loop. Setpoint reference in closed loop.	509	515
feedback_#	Par. 415	Feedback using the unit of measure selected in parameter 415.	511	517
freq_#	Hz	Drive output frequency.	512	518
motor_curr_#	Amp	Current being supplied to motor.	514	520
power_#	kW	Power being supplied to motor.	515	522
motor_volt_#	VAC	Voltage being supplied to motor.	517	524
dc_bus_volt_#	VDC	DC bus voltage of drive.	518	525
therm_motor_load_#	%	Calculated thermal load on motor. Trip point is 100%.	519	526
therm_inverter_load_#	%	Calculated thermal load on drive. Trip point is 100%.	520	527
term_53_analog_#	VDC	Voltage value on analog input Terminal 53.	522	529
term_54_analog_#	VDC	Voltage value on analog input Terminal 54 (for VLT 6000 only).	523	VLT 6000 only
term_60_analog_#	mA	Current value on analog input Terminal 60.	524	531
heatsink_temperature_#	°C	Drive heatsink temperature.	528	537
operating_hours_#	Hour	Number of hours power applied to drive.	600	600
run_hours_#	Hour	Number of hours drive applied power to motor.	601	601
kwh_counter_#	kWh	Output power of drive in hours.	602	602

**NOTE: # symbol represents drive ID number.**

## Binary Outputs from Drive (status)

BACnet REFERENCE NAME	SELECTION	VLT 6000 PARA NO.	VLT 2800 PARA NO.
current_status_#	<b>0=OK</b> 1=Limit	527	534
voltage_status_#	<b>0=OK</b> 1=Limit	527	534
motor_run_status_#	<b>0=Not Running</b> 1=Running	527	534
frequency_status_#	0=Out of Range <b>1=In Range</b>	527	534
control_status_#	0=Local <b>1=Remote</b>	527	534
reference_status_#	0=Not on Ref. <b>1=On Ref.</b>	527	534
warning_status_#	<b>0=OK</b> 1= Warning	527	534
trip_status_#	<b>0=OK</b> 1=Tripped	527	534
coast_status_#	0=Not Enabled <b>1=Enabled</b>	527	534
heatsink_temp_#	<b>0=OK</b> 1=Warning (for VLT 2800 only)	VLT 2800 only	540
vlt2800_term_33_#	<b>0=Off</b> 1=On (for VLT 2800 only)	VLT 2800 only	528
frequency_low_#	<b>0=OK</b> 1=Warning	531	540
frequency_high_#	<b>0=OK</b> 1=Warning	533	540
current_low_#	<b>0=OK</b> 1=Warning	531	540
current_high_#	<b>0=OK</b> 1=Warning	531	540
feedback_low_#	<b>0=OK</b> 1=Warning	531	540
feedback_high_#	<b>0=OK</b> 1=Warning	531	540
live_zero_error_#	<b>0=OK</b> 1=Warning	531	540
phase_loss_#	<b>0=OK</b> 1=Warning	531	540
drive_therm_overload_#	<b>0=OK</b> 1=Warning	531	540
motor_therm_overload_#	<b>0=OK</b> 1=Warning	531	540
current_limit_#	<b>0=OK</b> 1=Warning	531	540
external_fault_# (safety interlock)	<b>0=OK</b> 1=Alarm (for VLT 6000 only)	529	VLT 6000 only
over_temp_#	<b>0=OK</b> 1=Alarm	529	538
earth_fault_#	<b>0=OK</b> 1=Alarm (for VLT 6000 only)	529	VLT 6000 only
trip_lock_#	<b>0=OK</b> 1=Trip Lock	529	538
standby_#	<b>0=False</b> 1=True (for VLT 6000 only)	532	VLT 6000 only
jogging_#	<b>0=False</b> 1=True (for VLT 6000 only)	532	VLT 6000 only
hand_mode_#	<b>0=Auto</b> 1=Hand (for VLT 6000 only)	532	VLT 6000 only
off_#	<b>0=False</b> 1=True (for VLT 6000 only)	532	VLT 6000 only
local_ref_#	<b>0=False</b> 1=True (for VLT 6000 only)	532	VLT 6000 only
running_at_ref_#	<b>0=False</b> 1=True (for VLT 6000 only)	532	VLT 6000 only
sleep_mode_#	<b>0=False</b> 1=True (for VLT 6000 only)	532	VLT 6000 only

**NOTE: # symbol represents drive ID number.**

The values in bold are default values.



## Binary Outputs from Drive (continued)

BACnet REFERENCE NAME	SELECTION	VLT 6000 PARA NO.	VLT 2800 PARA NO.
reverse_#	<b>0=False</b> 1=True (for VLT 6000 only)	530	VLT 6000 only
vlt6000_term_33_#	<b>0=Off</b> 1=On (for VLT 6000 only)	521	VLT 6000 only
terminal_32_#	<b>0=Off</b> 1=On (for VLT 6000 only)	521	VLT 6000 only
terminal_29_#	<b>0=Off</b> 1=On (for VLT 6000 only)	521	VLT 6000 only
terminal_27_#	<b>0=Off</b> 1=On (for VLT 6000 only)	521	VLT 6000 only
terminal_19_#	<b>0=Off</b> 1=On (for VLT 6000 only)	521	VLT 6000 only
terminal_18_#	<b>0=Off</b> 1=On (for VLT 6000 only)	521	VLT 6000 only
terminal_17_#	<b>0=Off</b> 1=On (for VLT 6000 only)	521	VLT 6000 only
terminal_16_#	<b>0=Off</b> 1=On (for VLT 6000 only)	521	VLT 6000 only

**NOTE: # symbol represents drive ID number.**

The values in bold are default values.



---

**Danfoss**

8800 West Bradley Road  
P.O. Box 245041  
Milwaukee, Wisconsin 53224-9541  
Phone: (414) 355-8800 Fax: (414) 355-6117  
Toll free: (800) 621-8806

<http://www.namc.danfoss.com>

---